

## Very High-Speed CO<sub>2</sub> Sensor

### DESCRIPTION

The SprintIR®-R is a small footprint high flow through NDIR CO<sub>2</sub> sensor using state-of-the-art solid-state LED optical technology. The low power LEDs are manufactured in-house, giving GSS complete control of the CO<sub>2</sub> sensor signal chain.

The SprintIR®-R is designed for applications that need fast response time and high-speed measurement capability. The SprintIR®-R takes 50 readings per second, making it ideal for equipment that needs real-time CO<sub>2</sub> gas analysis or monitoring.

The sensor is available in multiple versions, capable of measuring CO<sub>2</sub> levels up to 100% concentration.

### FEATURES

- 50 readings per second
- High flow throughput capability
- Custom flow adaptor options
- 70ppm typical measurement accuracy
- Measurement range up to 100%
- Solid state NDIR LED optical technology
- UART control and data interface
- Built-in auto-zeroing

### APPLICATIONS

- Healthcare
- Food Packaging
- Sport Science
- CO<sub>2</sub> Fire Suppression Deployment

### BLOCK DIAGRAM

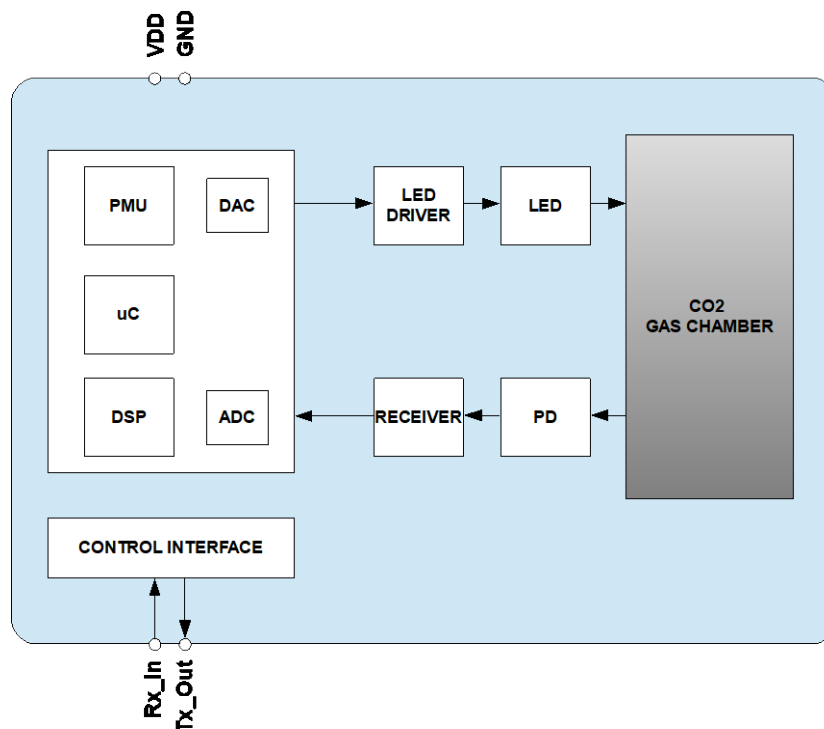

**Very High-Speed CO<sub>2</sub> Sensor**

**TABLE OF CONTENTS**

DESCRIPTION..... 1

FEATURES..... 1

APPLICATIONS..... 1

BLOCK DIAGRAM..... 1

ORDERING INFORMATION ..... 4

PACKAGE DRAWING: SprintIR®-R WITH FLOW PORT ADAPTOR ..... 5

PIN-OUT DESCRIPTION: SprintIR®-R..... 5

PACKAGE DRAWING: SprintIR®-R-M WITH MEMBRANE COVER ..... 6

PIN-OUT DESCRIPTION: SprintIR®-R..... 6

ABSOLUTE MAXIMUM RATINGS ..... 7

RECOMMENDED OPERATING CONDITIONS..... 7

MECHANICAL SEALING..... 7

CO<sub>2</sub> PERFORMANCE CHARACTERISTICS ..... 8

ELECTRICAL CHARACTERISTICS ..... 9

POWER CONSUMPTION - SprintIR®-R..... 9

RESPONSE TIME, FLOW RATE AND MEASUREMENT RATE - SprintIR®-R..... 10

    Measurement Rate ..... 10

    Gas Exchange Rate ..... 10

    Digital Filter Setting..... 10

METHOD OF OPERATION ..... 11

MODE 0 COMMAND MODE ..... 11

MODE 1 STREAMING MODE ..... 11

MODE 2 POLLING MODE..... 11

ZERO POINT SETTING ..... 14

ZERO IN A KNOWN GAS CONCENTRATION ..... 14

ZERO IN NITROGEN ..... 14

ZERO IN FRESH AIR..... 14

ZERO POINT ADJUSTMENT..... 14

AUTO-ZERO FUNCTION ..... 15

AUTO-ZEROING INTERVALS ..... 15

AUTO-ZERO SETTINGS..... 15

PRESSURE AND CONCENTRATION LEVEL COMPENSATION ..... 16

ALTITUDE COMPENSATION TABLE..... 16

CONTROL INTERFACE ..... 18

CONTROL INTERFACE TIMING - UART MODE ..... 18

UART COMMAND PROTOCOL..... 18

UART OPERATION ..... 18

UART INTERFACE SUMMARY ..... 19

CO<sub>2</sub> LEVEL MEASUREMENT VALUE - Z INFORMATION (0x5A) ..... 21

CO<sub>2</sub> LEVEL MEASUREMENT VALUE - z INFORMATION (0x7A) ..... 21

    ‘.’ COMMAND (0x2E)..... 21

K COMMAND..... 22

## Very High-Speed CO<sub>2</sub> Sensor

---

K COMMAND (0x4B) .....	22
DIGITAL FILTER COMMANDS .....	22
A COMMAND (0x41) .....	22
a COMMAND (0x61).....	22
ZERO POINT SETTING COMMANDS .....	23
F COMMAND (0x46).....	23
G COMMAND (0x47) .....	24
U COMMAND (0x55) .....	24
u COMMAND (0x75) .....	24
X COMMAND (0x58) .....	24
P COMMAND - CO <sub>2</sub> Level for Auto-zeroing.....	24
P COMMAND – CO <sub>2</sub> Level for Zero-Point Setting.....	25
AUTO-ZEROING INTERVALS .....	26
@ COMMAND (0x2E) .....	26
PRESSURE AND CONCENTRATION COMPENSATION .....	27
S COMMAND (0x53).....	27
s COMMAND (0x73) .....	27
MEASUREMENT DATA OUTPUTS .....	27
M COMMAND .....	28
Q COMMAND .....	28
SERIAL NUMBER AND FIRMWARE VERSION .....	28
Y COMMAND (0x59).....	28
CONNECTION DIAGRAM FOR UART INTERFACE .....	29
IMPORTANT NOTICE .....	30
ADDRESS .....	30
REVISION HISTORY .....	31
ABSOLUTE MAXIMUM RATINGS, MECHANICAL SEALING .....	31
PACKAGE DRAWING.....	31
Added 10% option.....	31

**Very High-Speed CO<sub>2</sub> Sensor**

**ORDERING INFORMATION**

**SPRINTIR-R-X-X**

X	Measurement Range
5	0-5%
10	0-10%
20	0-20%
60	0-60%
100	0-100%

X	Gas Cover
Blank	Flow through adaptor as standard
M	Membrane instead of flow adaptor

**Notes:**

1. Sensors are shipped individually
2. Custom flow through adaptors are available, contact GSS for options

**See separate data sheet for SprintIR®-R evaluation kit options.**

**Very High-Speed CO<sub>2</sub> Sensor**

**PACKAGE DRAWING: SprintIR®-R WITH FLOW PORT ADAPTOR**

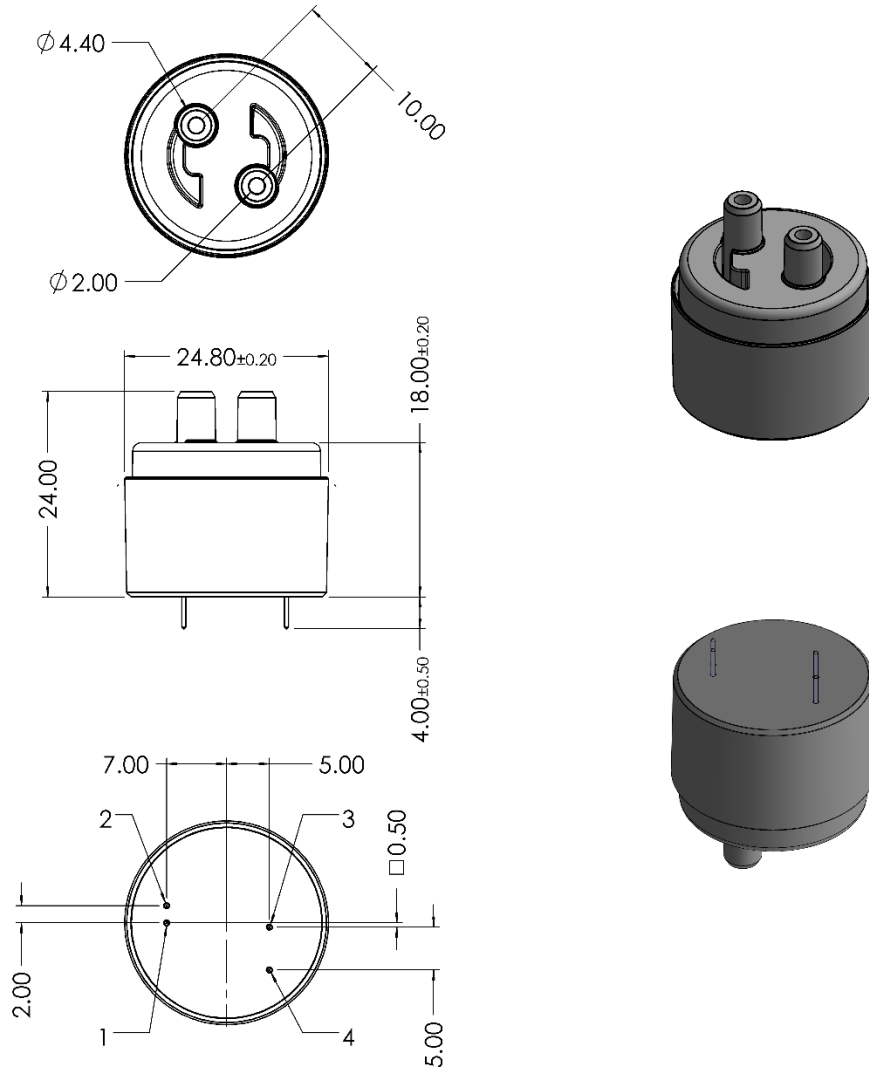

**Weight = ~5g**

**PIN-OUT DESCRIPTION: SprintIR®-R**

PIN	NAME	TYPE	DESCRIPTION
1	Rx_In	Digital Input	UART Receive Input
2	Tx_Out	Digital Output	UART Transmit Output
3	GND	Supply	Sensor ground
4	VDD	Supply	Sensor supply voltage

**Very High-Speed CO<sub>2</sub> Sensor**

**PACKAGE DRAWING: SprintIR®-R-M WITH MEMBRANE COVER**

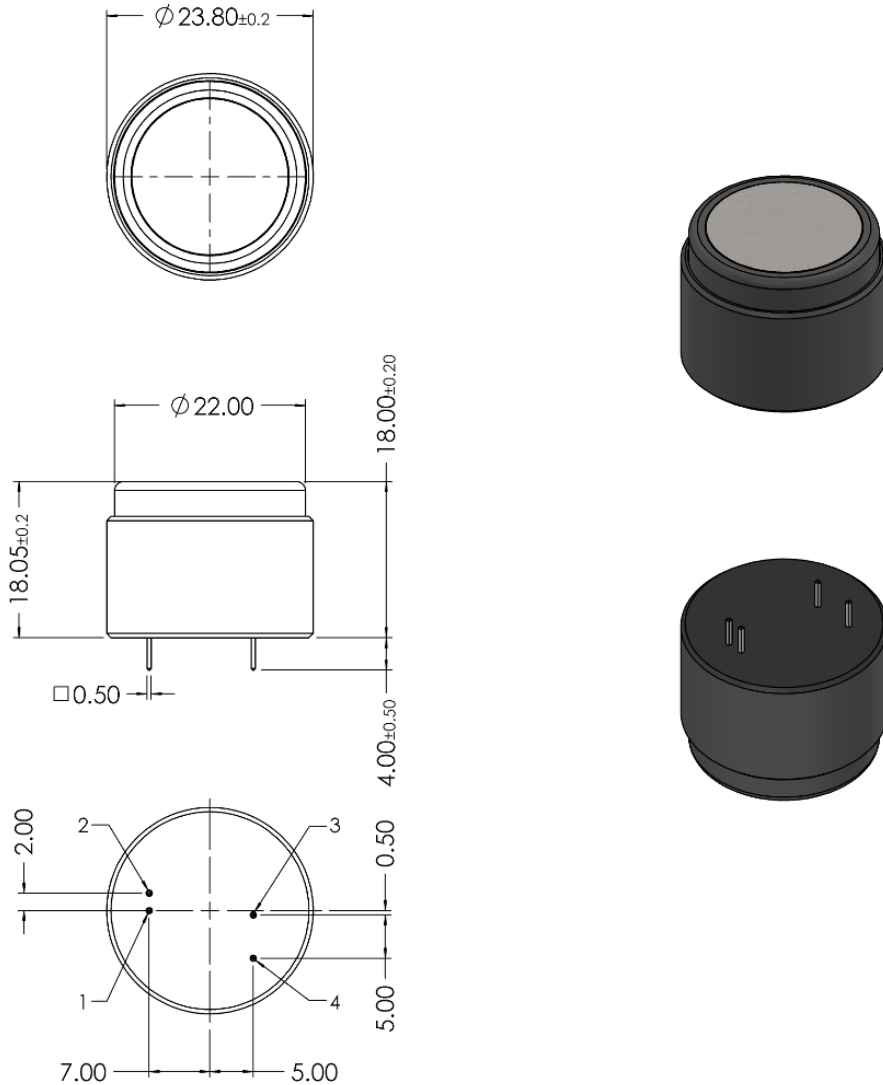

**Weight = ~5g**

**PIN-OUT DESCRIPTION: SprintIR®-R**

PIN	NAME	TYPE	DESCRIPTION
1	Rx_In	Digital Input	UART Receive Input
2	Tx_Out	Digital Output	UART Transmit Output
3	GND	Supply	Sensor ground
4	VDD	Supply	Sensor supply voltage

## Very High-Speed CO<sub>2</sub> Sensor

### ABSOLUTE MAXIMUM RATINGS

Absolute Maximum Ratings are stress ratings only. Permanent damage to the SprintIR®-R may be caused by continuously operating at or beyond these limits. The SprintIR®-R functional operating limits and guaranteed performance specifications are given at the test conditions specified.



ESD Sensitive Device. This sensor uses ESD sensitive components. It is therefore generically susceptible to damage from excessive static voltages. Proper ESD precautions must be taken during handling and storage of this device.

CONDITION	MIN	MAX
Supply Voltages	-0.3V	+6.0V
Voltage Range Digital Inputs	GND -0.3V	5V
Operating Temperature Range (T <sub>a</sub> ) - Standard	0°C	+50°C
Storage Temperature Range	-40°C	+70°C
Humidity Range (RH)	0	95%
Operating Ambient Pressure Range	500mbar	2bar

### RECOMMENDED OPERATING CONDITIONS

PARAMETER	SYMBOL	MIN	TYP	MAX	UNIT
Supply	VDD	3.25	3.3	5.5	V
Ground	GND		0		V

### MECHANICAL SEALING

CONDITION	MIN	MAX
Working Gauge Pressure <sup>1</sup>	0.3bar	
Burst Gauge Pressure <sup>2</sup>	2bar	

#### Test Conditions Unless Otherwise Specified

1. The mechanical sealing between the flow adaptor and sensor housing is tested by pressurising the gas chamber to 0.3bar. The pressure reading must not drop by more than 1mbar within 30 seconds
2. Guaranteed by design, not tested

## Very High-Speed CO<sub>2</sub> Sensor

### CO<sub>2</sub> PERFORMANCE CHARACTERISTICS

Test Conditions Unless Otherwise Specified

VDD = 3.3V, GND = 0V, RH = 0% non-condensing, T= 25°C, Pressure = 1013mbar, Flow Rate = 0.2l/minute

PARAMETER	SYMBOL	TEST CONDITIONS	MIN	TYP	MAX	UNIT
CO <sub>2</sub> measurement range			0		5	%
			0		20	%
			0		60	%
			0		100	%
Accuracy (0-5% sensor)		@25°C, @ 2% CO <sub>2</sub>			±(70, +5% of reading)	ppm
Accuracy (0-10% sensor)		@25°C, @ 9% CO <sub>2</sub>				
Accuracy (0-20% sensor)		@25°C, @ 12% CO <sub>2</sub>				
Accuracy (0-60% sensor)		@25°C, @ 20% CO <sub>2</sub>				
Accuracy (0-100% sensor)		@25°C, @ 60% CO <sub>2</sub>			±(300, +5% of reading)	ppm
Accuracy (Peak-Peak) 0-60%		@25°C		±(70, +5%)		ppm
		0°C to +50°C, after zero @25°C		±(70, +5%)		ppm
Accuracy (Peak-Peak) 0-100%		@25°C		±(300, +5%)		ppm
		0°C to +50°C, after zero @25°C		±(300, +5%)		ppm
CO <sub>2</sub> RMS Noise		Digital filter setting 16		6		ppm
Time to Valid Measurement After Power-On		Digital filter setting 16, dependent on digital filter setting	1.0	1.2		secs
Response Time		From 0ppm to T <sub>90</sub> default settings, limited @ 0.2l/min		20		ms
Repeatability		@25°C, 0-60%		±70, +5%		ppm
		@25°C, 0-100%		±300, +5%		ppm
Current Consumption		Peak current when sampling		35		mA
		Peak at turn-on		40		mA
		SLEEP Mode (K2 polling)		0.01		mA

## Very High-Speed CO<sub>2</sub> Sensor

---

**ELECTRICAL CHARACTERISTICS**

PARAMETER	SYMBOL	TEST CONDITIONS	MIN	TYP	MAX	UNIT
<b>Digital Input/Output</b>						
Input HIGH Level			1.8			V
Input LOW Level					1.0	V
Output HIGH Level		I <sub>OH</sub> = +1mA	2.6		3.0	V
Output LOW Level		I <sub>OL</sub> = -1mA			0.4	V

**POWER CONSUMPTION - SprintIR®-R**

Test Conditions Unless Otherwise Specified

VDD = 3.3V, GND = 0V, RH = 0% non-condensing, T= 25°C, Pressure = 1013mbar, Flow Rate = 0.2l/minute

SETTING	SYMBOL	TEST CONDITIONS	VDD		Total Power
			V	I (mA)	mW
Active, KO SLEEP mode, no measurement			3.3	0.01	0.03
Active, K1 mode whilst taking measurements		Default settings	3.3	21	70

## Very High-Speed CO<sub>2</sub> Sensor

---

### RESPONSE TIME, FLOW RATE AND MEASUREMENT RATE - SprintIR®-R

The SprintIR®-R response time is dependent on several interrelated factors.

#### Measurement Rate

The measurement rate is fixed at 50 readings per second.

#### Gas Exchange Rate

The most important factor is the gas exchange rate. This is the amount of time it takes for the gas to enter the CO<sub>2</sub> measurement chamber, measured and then replaced. The sensor has a gas measurement chamber volume of approximately 2.8ml. As a general rule of thumb, to properly exchange the gas in the chamber, there needs to be a x5 volume of gas passed through the sensor. Therefore, approximately 14ml of gas needs to flow through the sensor for each reading.

$$\text{Max Flow Rate (l/min)} = \frac{50 \text{ reading/s} * 60\text{s} * 14\text{ml}}{1000}$$

#### Digital Filter Setting

The sensor outputs both filtered and raw unfiltered CO<sub>2</sub> readings. If the filtered measurement data is used, the read rate will also depend on the filter setting or the algorithm to process the raw data.

## **Very High-Speed CO<sub>2</sub> Sensor**

---

### **METHOD OF OPERATION**

After power is applied to the SprintIR®-R, the sensor will automatically start to take CO<sub>2</sub> measurements using the Mode 1 default settings, where the sensor is pre-programmed to send CO<sub>2</sub> measurement data at 20 readings per second. The measurement rate is fixed at 50 readings per second at 38,400 baud rate. The sensor will return the previous CO<sub>2</sub> measurement results if the user requests more frequent measurements.

The SprintIR®-R has 3 potential modes of operation.

### **MODE 0 COMMAND MODE**

In this mode, the sensor is in a SLEEP mode, waiting for commands. No measurements are made. There is no latency in command responses. All commands that report measurements or alter the zero-point settings are disabled in Mode 0. Mode 0 is NOT retained after power cycling.

### **MODE 1 STREAMING MODE**

This is the factory default setting. Measurements are reported twice per second. Commands are processed when received, except during measurement activity, so there may be a time delay of up to 10ms in responding to commands.

### **MODE 2 POLLING MODE**

In polling mode, the sensor only reports readings when requested. The sensor will continue to take measurements in the background, but the output stream is suppressed until data is requested. The sensor will always power up in streaming or polling mode, whichever mode was used before the power cycle.

## Very High-Speed CO<sub>2</sub> Sensor

The CO<sub>2</sub> gas chamber is illuminated with a nominal 4.25um wavelength LED and the signal received using a photo-diode. The signal from the photo-diode is processed and filtered by the sensor to remove noise and provide an accurate CO<sub>2</sub> reading. High frequency noise coming from the sampling process is removed using a proprietary lowpass filter. The digital filter setting can be varied, allowing the user to reduce measurement noise at the expense of the measurement response time. The ideal digital filter setting is application specific and is normally a balance between CO<sub>2</sub> reading accuracy and response time. The SprintIR®-R sensor will also output the raw unfiltered CO<sub>2</sub> measurement data. This data can be post processed using alternative filter algorithms.

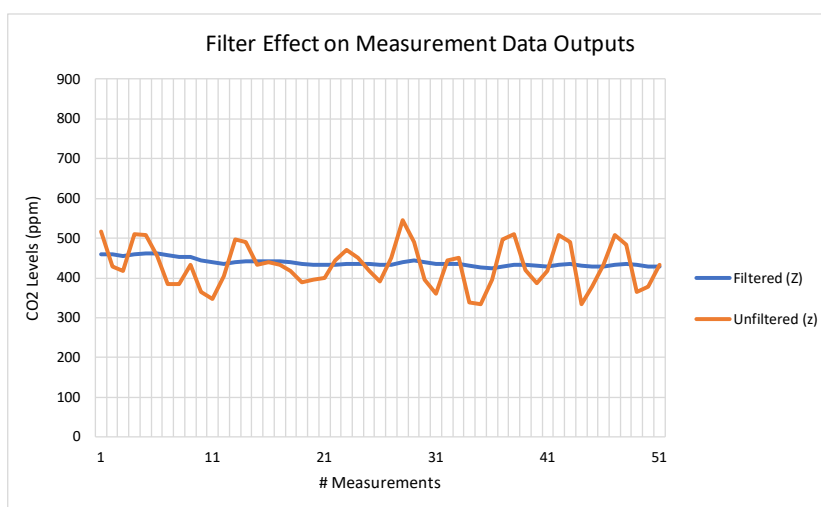

The graph above shows the effects of the filter on the CO<sub>2</sub> measurement data (Z or z). The unfiltered output is shown in orange and the filtered output shown in blue.

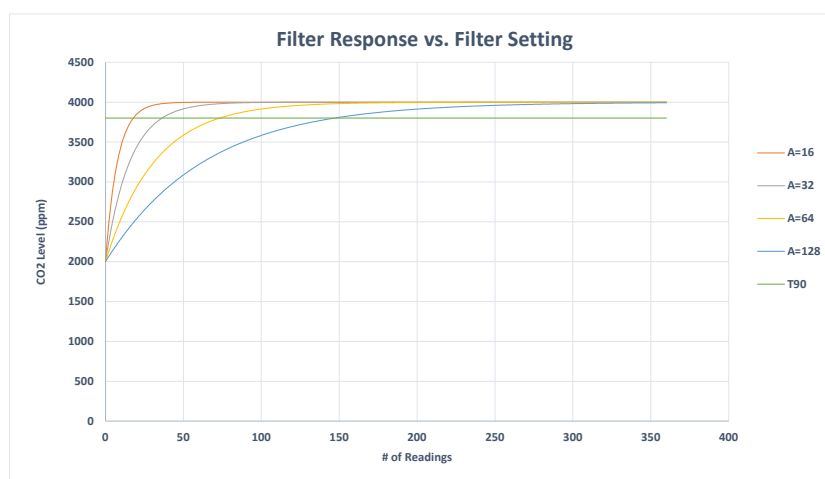

The graph above shows the effect of the filter on response times. Increasing the filter setting increases the measurement output response time. T<sub>90</sub> is the time to 90% of reading. The SprintIR®-R takes 50 readings per second. The flow rate was set at 0.2l/min.

## Very High-Speed CO<sub>2</sub> Sensor

---

Sampling noise is progressively reduced with higher digital filter settings. It is recommended the user sets the highest value digital filter setting without compromising the required flow rate.

Flow Rate	Recommended Digital Filter Setting 'a'
0.1litre/minute	128
0.5litre/minute	64
1litre/minute	32
5litre/minute	16

## Very High-Speed CO<sub>2</sub> Sensor

---

### ZERO POINT SETTING

There are a several methods available to the user to set the zero point of the sensor. The recommended user method is zero-point setting in a known gas concentration. In all cases, the best zero is obtained when the gas concentration is stable, and the sensor is at a stabilised temperature.

Note that zero-point settings are not cumulative and only the latest zero-point is effective. For example, there is no benefit in zeroing in nitrogen, and then zeroing in a calibration gas. The sensor will store only the latest zero point.

To improve zeroing accuracy, the recommended digital filter setting is 32. See the 'A' command.

### ZERO IN A KNOWN GAS CONCENTRATION

Place the sensor in a known gas concentration, power up the sensor and allow time for the sensor temperature to stabilise, and for the gas to be fully diffused into the sensor.

Send the **ZERO IN A KNOWN GAS CONCENTRATION** command X to the sensor. The sensor will be zeroed using the known gas concentration level sent by the user. The concentration value written to the sensor must be scaled dependent on the sensor CO<sub>2</sub> measurement range. The multiplier for the scaling factor is set according to the range of the sensor, see the '.' command.

### ZERO IN NITROGEN

Place the sensor in nitrogen gas and allow time for the sensor temperature to stabilise and the gas to be fully diffused into the sensor. Send the **ZERO IN NITROGEN** command U to the sensor. The sensor is zeroed assuming a 0ppm CO<sub>2</sub> environment.

### ZERO IN FRESH AIR

If there is no calibration gas or nitrogen available, the sensor zero point can be set in fresh air. Ambient CO<sub>2</sub> concentrations in fresh air are typically 400ppm. The CO<sub>2</sub> concentration fresh air zero level is programmable over a range from 0ppm to the full scale of the sensor.

Place the sensor in a fresh air environment and allow time for the sensor temperature to stabilise, and for the fresh air to be fully diffused into the sensor. Power up the sensor, write the G command to the sensor. The concentration value written to the sensor must be scaled dependent on the sensor CO<sub>2</sub> measurement range. The sensor can use the default fresh air CO<sub>2</sub> concentration value (400ppm), or the user can write a different fresh air value to the sensor if desired.

### ZERO POINT ADJUSTMENT

If the CO<sub>2</sub> concentration and the sensor reported concentration are known, the zero point can be adjusted using the known concentration to fine tune the zero point. For example, if the sensor has been in an environment that has been exposed to outside air, and the sensor reading is known at

## Very High-Speed CO<sub>2</sub> Sensor

---

that time, the zero point can be fine-tuned to correct the reading. This is typically used to implement automated zeroing routines.

The known CO<sub>2</sub> concentration value and the reported CO<sub>2</sub> value from the sensor can be sent to the sensor using the **ZERO POINT ADJUSTMENT** command F.

### **AUTO-ZERO FUNCTION**

The sensor has a built-in auto-zero function. In order to function correctly, the sensor must be exposed to typical background levels (400-450ppm) at least once during the auto-zero period. For example, many buildings will drop quickly to background CO<sub>2</sub> levels when unoccupied overnight or at weekends. The auto-zero function uses the information gathered during these periods to re-zero. The sensor will reset the 'zero' level every time it does an auto-zero. Auto-zero is disabled by default. If the sensor is powered down, the auto-zero is reset to default values.

The auto-zero function works in the same way as the **ZERO IN FRESH AIR** command. Auto-zero is disabled by default, but can be enabled to operate automatically, or zeroing can be forced. The user can also independently adjust the CO<sub>2</sub> level used for auto-zeroing. Typically, it is set to the same value as the **ZERO IN FRESH AIR** value, but it can also be set at a different level if desired.

### **AUTO-ZEROING INTERVALS**

The auto-zero period can be programmed by the user. The sensor can be programmed to undertake an initial auto-zero after power-on. Thereafter, the auto-zero period can be set independently of the start-up auto-zero time. Note, the zero settings are reset if the sensor is powered down.

### **AUTO-ZERO SETTINGS**

By default, the sensor will automatically 'zero' using the measured CO<sub>2</sub> level sampled during the auto-zeroing period. The user can alter the behaviour of the sensor as a result of the auto-zeroing process.

## Very High-Speed CO<sub>2</sub> Sensor

### PRESSURE AND CONCENTRATION LEVEL COMPENSATION

NDIR gas sensors detect the concentration of gas by measuring the degree of light absorption by the gas analyte. The degree of light absorption is converted into a concentration reported by the sensor.

The absorption process is pressure and gas concentration dependent. In general, as the pressure increases, the reported gas concentration also increases. As the pressure decreases, the reported concentration decreases. This effect takes place at a molecular level and is common to all NDIR gas sensors.

GSS sensors are calibrated at 1013mbar and 450ppm CO<sub>2</sub>. The reading will vary due to pressure and CO<sub>2</sub> concentration. It is possible to correct for the effects of pressure and concentration by setting a compensation value. This will apply a permanent correction to the output of the sensor, depending on the compensation value. The compensation value needs to be written to the sensor and will overwrite the default 1013mbar and 450ppm CO<sub>2</sub> value. The new compensation value will be used for all subsequent measurements and will be retained after a power cycle.

### ALTITUDE COMPENSATION TABLE

Altitude (ft.)	Altitude (m)	Pressure (mbar)	Sea Level Difference	% Change per	CO <sub>2</sub> Measurement Change (%)	Compensation Value
0	0	1,013	0	0.14	0	8,192
500	153	995	18	0.14	3	8,398
1,000	305	977	36	0.14	5	8,605
1,500	458	960	53	0.14	7	8,800
2,000	610	942	71	0.14	10	9,006
2,500	763	925	88	0.14	12	9,201
3,000	915	908	105	0.14	15	9,396
3,500	1,068	891	122	0.14	17	9,591
4,000	1,220	875	138	0.14	19	9,775
4,500	1,373	859	154	0.14	22	9,958
5,000	1,525	843	170	0.14	24	10,142
6,000	1,830	812	201	0.14	28	10,497
7,000	2,135	782	231	0.14	32	10,841
8,000	2,440	753	260	0.14	36	11,174
9,000	2,745	724	289	0.14	40	11,506
10,000	3,050	697	316	0.14	44	11,816

Other compensation values can be calculated using the following formula.

$$Compensation\ Value = 8192 + \left( \frac{Sea\ Level\ Difference * 0.14}{100} \right) * 8192$$

## Very High-Speed CO<sub>2</sub> Sensor

---

The pressure compensation values calculated above are only approximate and only valid for concentrations below 1%. For higher accuracy compensation, the sensor output must be adjusted for both pressure and concentration as the CO<sub>2</sub> level measured by the sensor is affected by both ambient pressure and gas concentration levels. To calculate the adjusted CO<sub>2</sub> level, use the following calculator.

The corrected CO<sub>2</sub> level (C2) =  $C1/(1+Y(1013-P))$ ,

where,

C1 = Concentration reading from sensor

P = Pressure in mbar

Where concentration < 1500ppm.

$$Y = 2.6661E-16 C1^4 - 1.1146E-12 C1^3 + 1.7397E-09 C1^2 - 1.2556E-06 C1 - 9.8754E-04$$

Where concentration >1500ppm.

$$Y = 2.37472E-30 C1^6 - 2.70695E-25 C1^5 + 1.24012E-20 C1^4 - 2.91716E-16 C1^3 + 3.62939E-12 C1^2 - 1.82753E-08 C1 - 1.35129E-03$$

## Very High-Speed CO<sub>2</sub> Sensor

### CONTROL INTERFACE

The SprintIR® family of sensors are controlled by writing and reading from the sensor via its UART interface. The Rx\_In and Tx\_Out pins are normally high, suitable for direct connection to a UART. If the sensor is to be read by a true RS232 device (e.g. a PC), it is necessary to pass through a level converter to step up/down the voltage and invert the signal.

### CONTROL INTERFACE TIMING - UART MODE

PARAMETER	SYMBOL	MIN	TYP	MAX	UNIT
Baud Rate			38,400		Bits/s
Data Bits			8		
Parity			None		
Stop Bits			1		
Hardware Flow Control			None		

### UART COMMAND PROTOCOL

All UART commands must be terminated with a carriage return and line feed <CR><LF>, hex 0x0D 0x0A. In this document, this is shown as '\r\n'. UART commands that take a parameter always have a space between the letter and the parameter. The sensor will respond with a '?' if a command is not recognised. The two most common causes are missing spaces or missing <CR><LF> terminators.

All command communications are in ASCII and are terminated by carriage return, line feed (0x0D 0x0A). This document uses the protocol "\r\n" to indicate the carriage return line feed. All responses from the sensor, including measurements, have a leading space (ASCII character 32).

The character '#' represents an ASCII representation of a numeric character (0-9). Note there is a space between the first letter and any parameter. For example, the X command reads "X space 2000 carriage return line feed".

### UART OPERATION

When initially powered, the sensor will immediately start to transmit a CO<sub>2</sub> reading on receiving any character.

The CO<sub>2</sub> measurement is reported as:

Z #####\r\n

where Z ##### shows the CO<sub>2</sub> concentration.

Note that all outputs from the sensor have a leading space.

## Very High-Speed CO<sub>2</sub> Sensor

**UART INTERFACE SUMMARY**

Syntax	Use	Example	Response	Comments
A ###\r\n	Set value of the digital filter	A 128\r\n	A 00128\r\n	See “Digital Filter”
a\r\n	Return the value of the digital filter	a\r\n	a 00128\r\n	See “Digital Filter”
F #####\r\n	Fine Tune the zero point	F 410 400\r\n	F 33000\r\n	See “Zero Point Setting”
G\r\n	Zero-point setting using fresh air	G\r\n	G 33000\r\n	See “Zero Point Setting”
K #\r\n	Switches the sensor between different modes	K 1\r\n	K 1\r\n	
M ###\r\n	Sets the number of measurement data types output by the sensor	M 6\r\n	M 6\r\n	See “Output Fields”
P 8 ###\r\n P 9 #\r\n	Sets value of CO <sub>2</sub> background concentration in ppm for auto-zeroing	P 8 1\r\n P 9 144\r\n		Two byte value, P 8 = MSB P 9 = LSB  400ppm in the example
P 10 ###\r\n P 11 #\r\n	Sets value of CO <sub>2</sub> background concentration in ppm used for zero- point setting in fresh air.	P 10 1\r\n P 11 144\r\n		Two byte value, P 8 = MSB P 9 = LSB  400ppm in the example
Q\r\n	Reports the latest measurement data types, as defined by ‘M’	Q\r\n	H 12345 T 12345 Z 00010\r\n	
S #####\r\n	Sets the pressure and concentration compensation value	S 8192\r\n	S 08192\r\n	See “Pressure and Concentration Compensation”
s\r\n	Returns the pressure and concentration compensation value	s\r\n	s 08192\r\n	See “Pressure and Concentration Compensation”
U\r\n	Zero-point setting using nitrogen	U\r\n	U 33000\r\n	See “Zero Point Setting”
u #####\r\n	Manual setting of the zero point.	u 32997\r\n	u 32997\r\n	See “Zero Point Setting”
X #####\r\n	Zero-point setting using a known gas calibration	X 2000\r\n	X 32997\r\n	See “Zero Point Setting”
Y\r\n	Return firmware version and sensor serial number	Y\r\n	Returns <u>two</u> lines	
Z\r\n	Return the most recent filtered CO <sub>2</sub> measurement in ppm	Z\r\n	Z 01521\r\n	

## Very High-Speed CO<sub>2</sub> Sensor

---

Syntax	Use	Example	Response	Comments
z\r\n	Return the most recent unfiltered CO <sub>2</sub> measurement in ppm	z\r\n	Z 01521\r\n	
@ #.#.#.#\r\n	Sets the timing for initial and interval auto-zeroing periods	@ 1.0 8.0\r\n	@ 1.0 8.0\r\n	See <b>"Auto-zeroing"</b> for details
@ r\r\n	Returns the auto-zeroing configuration	@ 1.0 8.0\r\n	@ 1.0 8.0\r\n	See <b>"Auto-zeroing"</b> for details
@ #r\r\n	Switch Auto-zeroing on or off	@ 0\r\n	@ 0\r\n	See <b>"Auto-zeroing"</b> for details
.\r\n	Returns the scaling factor multiplier required to convert the Z or z output to ppm	.\r\n	. 00010\r\n	Multiply by 10 in the example

## Very High-Speed CO<sub>2</sub> Sensor

### CO<sub>2</sub> LEVEL MEASUREMENT VALUE - Z INFORMATION (0x5A)

<b>Description</b>	Reports the latest filtered CO <sub>2</sub> measurement
<b>Syntax</b>	ASCII Character 'Z', terminated by 0x0D 0x0A (CR & LF)
<b>Example</b>	Z\r\n
<b>Response</b>	Z 00521\r\n

This value needs to be multiplied by the appropriate scaling factor to derive the ppm value. See the '.' command.

### CO<sub>2</sub> LEVEL MEASUREMENT VALUE - z INFORMATION (0x7A)

The sensor is also capable of reporting the real time unfiltered CO<sub>2</sub> measurement value.

<b>Description</b>	Reports the unfiltered CO <sub>2</sub> measurement
<b>Syntax</b>	ASCII Character 'z', terminated by 0x0D 0x0A (CR & LF)
<b>Example</b>	z\r\n
<b>Response</b>	z 00521\r\n

### '.' COMMAND (0x2E)

To calculate the measurement value in ppm, the 'Z' or 'z' value, they must be converted into ppm by using the '.' multiplier factor. This multiplier will depend on the full-scale measurement range of the sensor. The multiplier is related to the full-scale range of the sensor.

The multiplier must also be used when sending CO<sub>2</sub> concentration levels to the sensor, for example when setting the fresh air CO<sub>2</sub> concentration value. The '.' Command can also be used to read back the scaling factor.

For example, if the user wants to zero the sensor in a known concentration of gas (e.g. 450ppm), the value written to the sensor must be 450/scaling factor.

<b>Description</b>	Returns a number indicating what multiplier must be applied to the Z CO <sub>2</sub> 2 measurement output to convert it into ppm.
<b>Syntax</b>	ASCII character '.', terminated by 0x0D 0x0A ( CR & LF )
<b>Example</b>	.\r\n
<b>Response</b>	. 00010\r\n (this number is variable, usually 10)

Measurement Range of Sensor	CO <sub>2</sub> Measurement Scaling Factor (Z)	CO <sub>2</sub> Measurement Output Units	Example
0 – 60%	10	ppm/10	Z 01200 = 12000ppm = 1.2%
0 – 100%	100	ppm/100	Z 01500 = 15000ppm = 15%

## Very High-Speed CO<sub>2</sub> Sensor

---

**K COMMAND**

Command	Use	Default	Range	Example	Response	Comments
K #\r\n	Switches the sensor between different control modes	1		K 1\r\n	K 1\r\n	<i>See 'K' Commands</i>

**K COMMAND (0x4B)**

<b>Description</b>	Sets the control interface mode					
<b>Syntax</b>	ASCII character 'K', SPACE, mode number, terminated by 0x0D 0x0A (CR & LF)					
<b>Example</b>	K 1\r\n					
<b>Response</b>	K 00001\r\n (this number is variable)					

**DIGITAL FILTER COMMANDS**

Command	Use	Default	Range	Example	Response	Comments
A ###\r\n	Set value of the digital filter	16	0 - 65635	A 16\r\n	A 00016\r\n	
a\r\n	Return value of digital filter		0 - 65365	a\r\n	a 00016\r\n	

**A COMMAND (0x41)**

<b>Description</b>	Set the value for the digital filter					
<b>Syntax</b>	ASCII character 'A', SPACE, decimal, terminated by 0x0D 0x0A (CR & LF)					
<b>Example</b>	A 16\r\n					
<b>Response</b>	A 00016\r\n (this number is variable)					

**a COMMAND (0x61)**

<b>Description</b>	Set the value for the digital filter					
<b>Syntax</b>	ASCII character 'A', SPACE, decimal, terminated by 0x0D 0x0A (CR & LF)					
<b>Example</b>	A 16\r\n					
<b>Response</b>	A 00016\r\n (this number is variable)					

## Very High-Speed CO<sub>2</sub> Sensor

**ZERO POINT SETTING COMMANDS**

Command	Use	Default	Range	Example	Response	Comments
F ##### #####\r\n	Fine Tune the zero point		Range of sensor	F 410 400\r\n	F 33000\r\n	See <b>"Zero Point Setting"</b>
G\r\n	Zero-point setting using fresh air			G\r\n	G 33000\r\n	See <b>"Zero Point Setting"</b>
U\r\n	Zero-point setting using nitrogen			U\r\n	U 33000\r\n	See <b>"Zero Point Setting"</b>
u #####\r\n	Manual setting of the zero point			u 32997\r\n	u 32997\r\n	See <b>"Zero Point Setting"</b>
X #####\r\n	Zero-point setting using a known gas concentration		Range of sensor	X 2000\r\n	X 32997\r\n	See <b>"Zero Point Setting"</b>
P 8 ###\r\n P 9 #\r\n	Sets value of CO <sub>2</sub> background concentration in ppm for auto-zeroing	P 8 1\r\n P 9 144\r\n				Two byte value, P 8 = MSB P 9 = LSB  400ppm in the example
P 10 ###\r\n P 11 #\r\n	Sets value of CO <sub>2</sub> background concentration in ppm used for zero- point setting in fresh air.	P 10 1\r\n P 11 144\r\n				Two byte value, P 8 = MSB P 9 = LSB  400ppm in the example

**F COMMAND (0x46)**

<b>Description</b>	Sets the zero-point using a known reading and a known CO <sub>2</sub> concentration terminated by 0x0D 0x0A (CR & LF)
<b>Syntax</b>	ASCII character 'F', SPACE, then the reported gas concentration, SPACE, then the actual gas concentration, terminated by 0x0D 0x0A (CR & LF)
<b>Example</b>	F 41 39\r\n
<b>Response</b>	F 33000\r\n (the numbers are variable)

## Very High-Speed CO<sub>2</sub> Sensor

---

### G COMMAND (0x47)

<b>Description</b>	Sets the zero point assuming the sensor is in fresh air (typically 400ppm CO <sub>2</sub> , but level can be set by user – see P commands.)
<b>Syntax</b>	ASCII character 'G' terminated by 0x0D 0x0A (CR & LF)
<b>Example</b>	G\r\n
<b>Response</b>	G 33000\r\n (the number is variable)

### U COMMAND (0x55)

<b>Description</b>	Sets the zero point assuming the sensor is in 0ppm CO <sub>2</sub> such as nitrogen.
<b>Syntax</b>	ASCII Character 'U' terminated by 0x0D 0x0A (CR & LF)
<b>Example</b>	U\r\n
<b>Response</b>	U 32767\r\n (the number is variable)

### u COMMAND (0x75)

<b>Description</b>	Forces a specific zero set point value. Input value is scaled by CO <sub>2</sub> value multiplier, see '.' command.
<b>Syntax</b>	ASCII character 'u', SPACE, then the gas concentration, terminated by 0x0D 0x0A (CR & LF)
<b>Example</b>	u 32767\r\n
<b>Response</b>	u 32767\r\n

### X COMMAND (0x58)

<b>Description</b>	Sets the zero point with the sensor in a known concentration of CO <sub>2</sub> . Input value is scaled by CO <sub>2</sub> value multiplier, see '.' command.
<b>Syntax</b>	ASCII character 'X', SPACE, then the gas concentration, terminated by 0x0D (CR & LF)
<b>Example</b>	X 1000\r\n
<b>Response</b>	X 33000\r\n (the number is variable).

### P COMMAND - CO<sub>2</sub> Level for Auto-zeroing

<b>Description</b>	Sets the value of CO <sub>2</sub> in ppm used for auto-zeroing. Input value is scaled by CO <sub>2</sub> value multiplier, see '.' command.
<b>Syntax</b>	ASCII character 'P', SPACE, then 8, SPACE, then MSB terminated by 0x0D 0x0A (CR & LF)  ASCII character 'P' then a space, then 9, then a space, then LSB terminated by 0x0D 0x0A (CR & LF)
<b>Example</b>	P 8 0\r\n P 9 40\r\n
<b>Response</b>	p 8 0\r\n p 9 40\r\n

## Very High-Speed CO<sub>2</sub> Sensor

The value is entered as a two-byte word, MSB first.

MSB = Integer (Concentration/256)

LSB = Concentration – (256\*MSB)

In the above example, target CO<sub>2</sub> background concentration is 400ppm.

MSB = Integer (400/256) = 1

LSB = 400 – 256 = 144

### P COMMAND – CO<sub>2</sub> Level for Zero-Point Setting

<b>Description</b>	Sets value of CO <sub>2</sub> in ppm for zero-point setting in fresh air. Input value is scaled by CO <sub>2</sub> value multiplier, see '.' command.
<b>Syntax</b>	ASCII character 'P', SPACE, then 10, SPACE, then MSB terminated by 0x0D 0x0A (CR & LF)  ASCII character 'P', SPACE, then 11, SPACE, then LSB terminated by 0x0D 0x0A (CR & LF)
<b>Example</b>	P 10 7\r\n P 11 208\r\n
<b>Response</b>	p 10 7\r\n p 11 208\r\n

MSB = Integer (Concentration/256)

LSB = Concentration – (256\*MSB)

In the above example, target zero-point CO<sub>2</sub> concentration is 2000ppm.

MSB = Integer (2000/256) = 7

LSB = 2000 – (256\*MSB) = 208

## Very High-Speed CO<sub>2</sub> Sensor

---

**AUTO-ZEROING INTERVALS**

UART Command	Use	Default	Range	Example	Response	Comments
@ #.#.#.#\r\n	Auto-zeroing interval settings			@ 1.0 8.0\r\n	@ 1.0 8.0\r\n	See "Auto-zeroing" for details

**@ COMMAND (0x2E)**

<b>Description</b>	Set the 'Initial Interval' and 'Regular Interval' for auto-zeroing events.
<b>Syntax</b>	ASCII character '@', SPACE, decimal, SPACE, decimal terminated by 0x0D 0x0A (CR & LF)
<b>Example</b>	@ 1.0 8.0\r\n
<b>Response</b>	@ 1.0 8.0\r\n (the number mirrors the input value)

Both the initial interval and regular interval are given in days. Both must be entered with a decimal point and one figure after the decimal point. In the above example, the auto-zero interval is set to 8 days, and the initial interval set to 1 day.

To disable auto-zero, send @ 0\r\n.

To start an auto-zero immediately, send 65222\r\n.

To determine the auto-zero configuration, send @\r\n.

## Very High-Speed CO<sub>2</sub> Sensor

### PRESSURE AND CONCENTRATION COMPENSATION

UART Command	Use	Default	Range	Example	Response	Comments
S #####\r\n	Sets the pressure and concentration compensation value	8192	0-65536	S 8192\r\n	S 08192\r\n	See <i>“Pressure and Concentration Compensation”</i>
s\r\n	Returns the pressure and concentration compensation value			s\r\n	s 08192\r\n	See <i>“Pressure and Concentration Compensation”</i>

### S COMMAND (0x53)

<b>Description</b>	Set the 'Pressure and Concentration Compensation' value
<b>Syntax</b>	ASCII character 'S', SPACE, decimal, terminated by 0x0D 0x0A (CR & LF)
<b>Example</b>	S 8192\r\n
<b>Response</b>	S 8192\r\n (the number mirrors the input value)

### s COMMAND (0x73)

<b>Description</b>	Reports the 'Pressure and Concentration Compensation' value.
<b>Syntax</b>	ASCII Character 's', terminated by 0x0D 0x0A (CR & LF)
<b>Example</b>	s\r\n
<b>Response</b>	s 8192\r\n

### MEASUREMENT DATA OUTPUTS

The SprintIR®-R sensor can provide filtered and unfiltered CO<sub>2</sub> data as a single string of data.

UART Command	Use	Default	Range	Example	Response	Comments
M #####\r\n	Sets the number of measurement data types output by the sensor. ##### is the mask value	M 04164\r\n		See <i>“Output Fields”</i>	M #####\r\n	Sets the number of measurement data types output by the sensor

Measurement Parameter	Field Identifier	Mask Value
CO <sub>2</sub> (Filtered)	Z	4
CO <sub>2</sub> (Unfiltered)	z	2

The required mask value is the sum of the 'Mask Value' for each field required. To output filtered and unfiltered CO<sub>2</sub> data, set M=6.

## Very High-Speed CO<sub>2</sub> Sensor

---

**M COMMAND**

<b>Description</b>	Sets the type and number of data outputs
<b>Syntax</b>	ASCII character 'M', terminated by 0x0D 0x0A ( CR & LF )
<b>Example</b>	M\r\n
<b>Response</b>	M 04164\r\n

**Q COMMAND**

<b>Description</b>	Reports the number of output data fields
<b>Syntax</b>	ASCII character 'Q', SPACE, then Mask Value, terminated by 0x0D 0x0A ( CR & LF )
<b>Example</b>	Q\r\n
<b>Response</b>	Z 00006\r\n

**SERIAL NUMBER AND FIRMWARE VERSION**

UART Command	Use	Default	Range	Example	Response	Comments
Y\r\n	Return firmware version and sensor serial number			Y\r\n	Returns <u>two</u> lines	

**Y COMMAND (0x59)**

<b>Description</b>	The present version string for the firmware and serial number of the sensor.
<b>Syntax</b>	ASCII character 'Y', terminated by 0x0D 0x0A ( CR & LF )
<b>Example</b>	Y\r\n
<b>Response</b>	Y,Jan 30 2013,10:45:03,AL17\r\n ingB 00233 00000\r\n

N.B. This command returns two lines split by a carriage return line feed and terminated by a carriage return line feed. This command requires that the sensor has been stopped (see 'K' command).

## Very High-Speed CO<sub>2</sub> Sensor

---

### CONNECTION DIAGRAM FOR UART INTERFACE

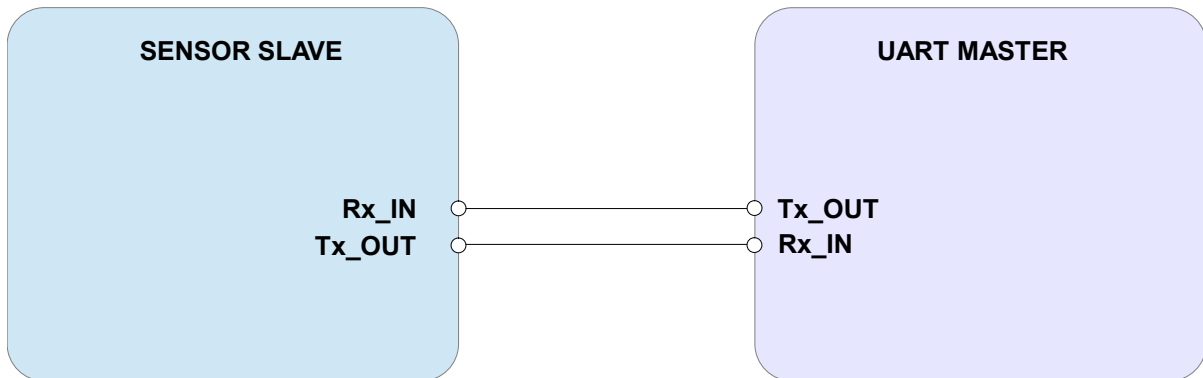

## Very High-Speed CO<sub>2</sub> Sensor

---

### IMPORTANT NOTICE

Gas Sensing Solutions Ltd. (GSS) products and services are sold subject to GSS's terms and conditions of sale, delivery and payment supplied at the time of order acknowledgement. GSS warrants performance of its products to the specifications in effect at the date of shipment. GSS reserves the right to make changes to its products and specifications or to discontinue any product or service without notice.

Customers should therefore obtain the latest version of relevant information from GSS to verify that the information is current. Testing and other quality control techniques are utilised to the extent GSS deems necessary to support its warranty. Specific testing of all parameters of each device is not necessarily performed unless required by law or regulation. In order to minimise risks associated with customer applications, the customer must use adequate design and operating safeguards to minimise inherent or procedural hazards. GSS is not liable for applications assistance or customer product design. The customer is solely responsible for its selection and use of GSS products. GSS is not liable for such selection or use nor for use of any circuitry other than circuitry entirely embodied in a GSS product.

GSS products are not intended for use in life support systems, appliances, nuclear systems or systems where malfunction can reasonably be expected to result in personal injury, death or severe property or environmental damage. Any use of products by the customer for such purposes is at the customer's own risk.

GSS does not grant any licence (express or implied) under any patent right, copyright, mask work right or other intellectual property right of GSS covering or relating to any combination, machine, or process in which its products or services might be or are used. Any provision or publication of any third party's products or services does not constitute GSS's approval, licence, warranty or endorsement thereof. Any third party trademarks contained in this document belong to the respective third party owner.

Reproduction of information from GSS datasheets is permissible only if reproduction is without alteration and is accompanied by all associated copyright, proprietary and other notices (including this notice) and conditions. GSS is not liable for any unauthorised alteration of such information or for any reliance placed thereon.

Any representations made, warranties given, and/or liabilities accepted by any person which differ from those contained in this datasheet or in GSS's standard terms and conditions of sale, delivery and payment are made, given and/or accepted at that person's own risk. GSS is not liable for any such representations, warranties or liabilities or for any reliance placed thereon by any person.

### ADDRESS

Gas Sensing Solutions Ltd.  
Grayshill Road  
Cumbernauld  
G68 9HQ  
United Kingdom

## Very High-Speed CO<sub>2</sub> Sensor

---

### REVISION HISTORY

DATE	RELEASE	DESCRIPTION OF CHANGES	PAGES
16/04/2020	4.0	First revision	All
29/04/2020	4.1	Changed auto-zero explanation	All
10/06/2020	4.2	ABSOLUTE MAXIMUM RATINGS, MECHANICAL SEALING	P.7
21/07/2020	4.3	PACKAGE DRAWING	P.5
21/09/2020	4.4	Added 10% option	P.4, P.8