

1. SPECIFICATION 性能规格

PARAMETER 参数	NOTE 符号	MIN. 最小值	NOM. 额定值	MAX. 最大值	UNITS 单位
SUPPLY VOLTAGE 供电电压	Vbat	6	12	16	V
OPERATING TEMPERATURE 工作温度	T	-40	-	105	°C
OPERATING PRESSURE 工作压力	P	50	-	165	kPaA
PROOF PRESSURE 安全压力	Pproof	-	400	-	kPaA
SUPPLY CURRENT IN HIGH POWER CONSUMPTION MODE 高功耗模式下供电电流*	Ibat_H	-	18	-	mA
AVERAGE SUPPLY CURRENT IN LOW POWER CONSUMPTION MODE (WORKING PERIOD: 1000ms) 低功耗模式下平均供电电流 (工作周期为1000ms) *	Ibat_L	-	<0.2	-	mA
SUPPLY CURRENT IN DEEP SLEEP MODE 深度休眠模式下供电电流*	Ibat_D	-	-	0.01	mA
HIGH CLAMP 高钳位值	-	-	167.9	-	kPaA
LOW CLAMP 低钳位值	-	-	47.1	-	kPaA
PRESSURE RESPONSE TIME 压力响应时间	T1000	-	-	62	ms
MOUNTING TORQUE 安装力矩	-	4.5	5	5.5	Nm

*SUPPLY CURRENT IS DEFINED UNDER THE CONDITION OF T=23°C AND Vbat=12V
 AVERAGE SUPPLY CURRENT IN LOW POWER CONSUMPTION MODE IS ALSO DEPENDENT ON ITS WORKING PERIOD(100ms~1000ms), SEE BELOW TABLE
 供电电流的定义条件均为: T=23°C 和 Vbat=12V
 低功耗模式下平均供电电流同时取决于其工作周期(100ms~1000ms), 具体见下表

WORKING PERIOD 工作周期/ms	AVERAGE SUPPLY CURRENT 平均供电电流/mA
100	0.98
200	0.53
300	0.38
400	0.3
500	0.25
600	0.22
700	0.2
800	0.19
900	0.17
1000	0.16

2. OUTPUT TRANSFER FUNCTION 输出传递函数

TYPE OF OUTPUT SIGNAL 输出信号方式 : CAN 2.0
 Nout=P*10
 P: OUTPUT PRESSURE 输出压力 [kPaA]

3. OVERALL ERROR 总误差:

BETWEEN 0°C~85 °C : ±1.2 kPa
 AT -40 °C AND 105°C : ±2.3 kPa

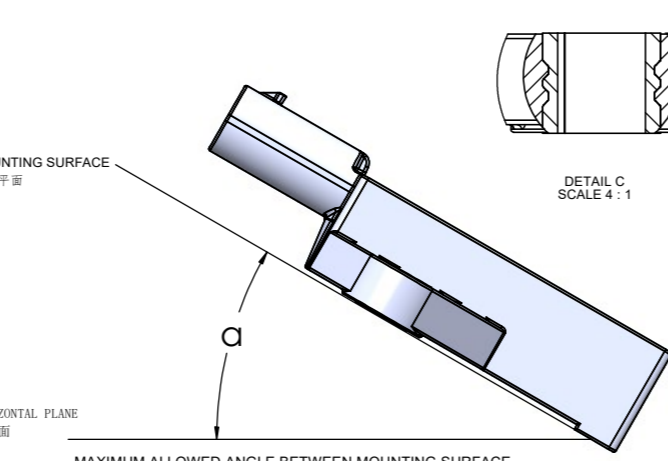
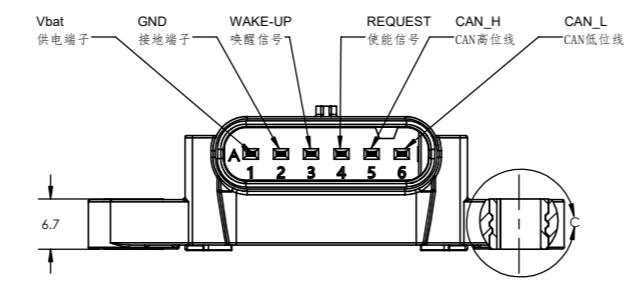
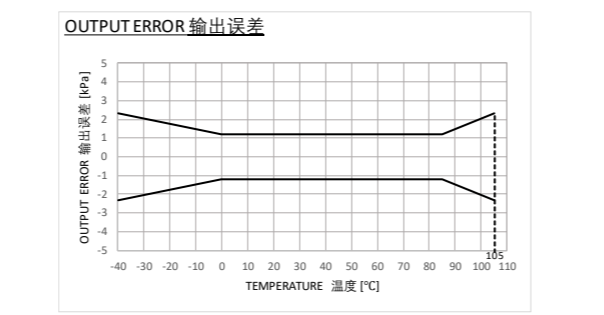

MOUNTING SURFACE 安装平面
 HORIZONTAL PLANE 水平面
 MAXIMUM ALLOWED ANGLE BETWEEN MOUNTING SURFACE AND HORIZONTAL PLANE IN ANY DIRECTION IS: 90°
 KEEP THE PRESSURE INLET DOWNSIDE TO PREVENT BLOCKING
 安装方向与水平面的夹角在任意方向上不大于: 90°
 即保持压力进气孔朝下, 避免进气孔堵塞。

4. BPS ELECTRICAL INTERFACE BPS 电气接口

4.1 WAKE-UP INTERFACE 唤醒电路接口

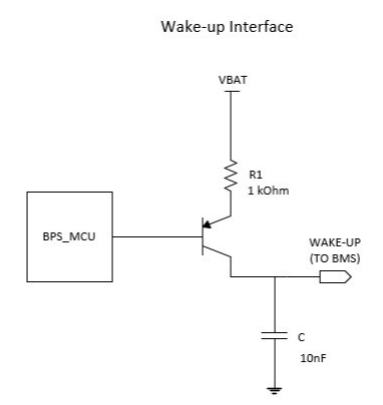

4.2 REQUEST INTERFACE 使能电路接口

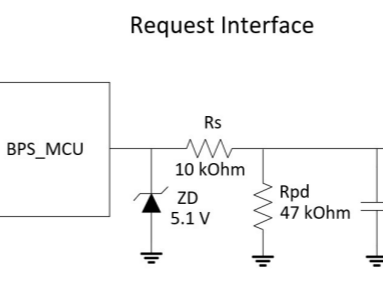

4.3 CAN INTERFACE CAN信号接口

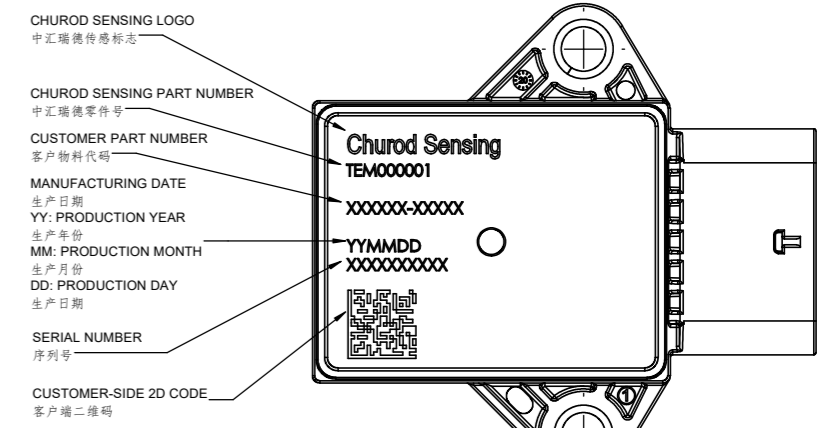
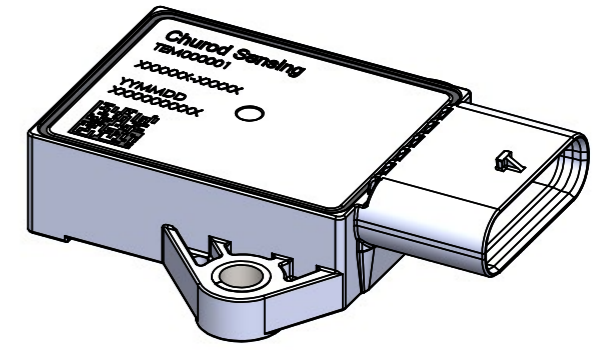
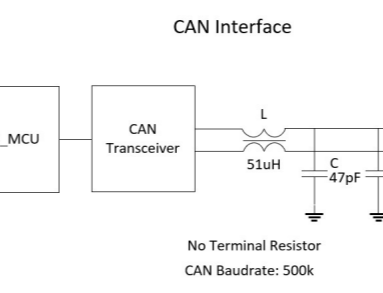

- ### NOTES:
- DETAILED SPECIFICATION SEE TEM000001-PSP;
 - TERMINAL OF MATING CONNECTOR MUST BE Ag PLATED, AND WIRE SEAL SHALL BE APPLIED ACCORDING TO IP RATING REQUIREMENTS;
 - MUST BE INTSALLED BY 2PCS BOLTS SIMULTANEOUSLY, ONLY 1PC BOLT IS FORBIDDEN;
 - PRODUCT INFORMATION IS MARKED ON COVER BY LASER CODING;
 - IN THE EVENT OF CONFLICT BETWEEN THE CHINESE AND ENGLISH LANGUAGE, THE CHINESE LANGUAGE SHALL TAKE PRECEDENCE.

- ### 注释:
- 详细规格参照TEM000001-PSP;
 - 对接插件必须使用镀银端子, 导线密封胶应根据IP等级要求而选用;
 - 必须同时使用2枚螺栓进行安装, 不允许仅使用1枚螺栓;
 - 产品信息以激光打码的方式标记于封盖;
 - 如中英文内容产生歧义, 应以中文为准。

CHARACTERISTIC NAME	DRAWING SYMBOL	DESCRIPTION	(INITIAL) SHORT TERM Cpk	LONG TERM Ppk
ISO 26262 FUNCTIONAL SAFETY RELATED SPECIAL	+	A CHARACTERISTIC OF AN ITEM, ELEMENT OR PRODUCTION PROCESS FOR WHICH REASONABLY FORESEEABLE DEVIATION COULD AFFECT, CONTRIBUTE TO OR CAUSE ANY POTENTIAL REDUCTION OF FUNCTIONAL SAFETY.	≥ 1.67	≥ 1.67
CRITICAL	△	CONTROL ITEM PRODUCTS HAVE CRITICAL CHARACTERISTICS THAT MAY AFFECT SAFE VEHICLE/PRODUCT OPERATION AND/OR COMPLIANCE WITH GOVERNMENT REGULATIONS. UNIQUE SYMBOLS IDENTIFYING SAFETY AND REGULATORY CHARACTERISTICS.	≥ 1.67	≥ 1.67
SIGNIFICANT	◇	SIGNIFICANT CHARACTERISTICS ARE THOSE PRODUCT PARAMETERS AND REQUIREMENTS THAT ARE IMPORTANT FOR CUSTOMER SATISFACTION (FORM, FIT AND FUNCTION) AND FOR WHICH QUALITY PLANNING ACTIONS MUST BE ADDRESSED ON A CONTROL PLAN.	≥ 1.67	≥ 1.33
SPC STANDARD	⊙	USED TO SPECIFY ONGOING SPC METHODOLOGIES TO BE PERFORMED.	≥ 1.67	≥ 1.33
		NON-KEY CHARACTERISTIC - STANDARD DIMENSION VS. STANDARD (INCL. TOLERANCE)	FIRST ARTICLE INSPECTION OK FIRST PART	FIRST ARTICLE INSPECTION OK FIRST PART

ALL RIGHT RESERVED
 NEITHER THIS PRINT NOR THE INFORMATION CONTAINED HEREON IS TO BE USED AGAINST THE INTERESTS OF CHUROD SENSING TECHNOLOGIES OR AGAINST THE INTERESTS OF ANY OF ITS AFFILIATED COMPANIES OR WHOLLY OWNED SUBSIDIARIES.

528 FANGQIAO ROAD
 XIANGCHENG DISTRICT
 SUZHOU CHINA

中汇瑞德
 CHUROD SENSING

TITLE: ENVELOPE DRAWING SMART BPS

DRAWN	JOHNSON WANG	INTERPRET DIMENSIONING AND TOLERANCING PER ASME Y14.5-2009. UNLESS OTHERWISE SPECIFIED DIMENSIONS ARE IN MILLIMETERS.	SIZE	NUMBER	REV
DATE	15-MAR-2022		A1	TEM000001-ENV	1
ENGINEER	JOHNSON WANG	TOLERANCES	SCALE	2:1	SHEET
DATE	15-MAR-2022	LINEAR			1 OF 1
APPROVED	JOHN XT	ANGULAR			
DATE	15-MAR-2022	±0.5			
APPROVED		±3°			
DATE					
		DO NOT SCALE DRAWING			
		METHOD THIRD ANGLE PROJECTOR			

CONNECTOR DESIGN ACCORDING TO USCAR 120-S-006-1-202 KEYING OPTION: A, TO MATE WITH TE P/N 1-1718646-1 OR 1924292-5
 电气接插件设计依据: USCAR 120-S-006-1-202 A型,
 应索料号1-1718646-1或1924292-5 配对使用

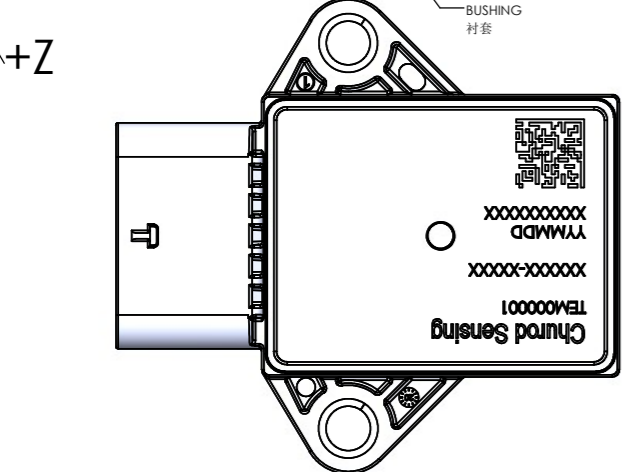
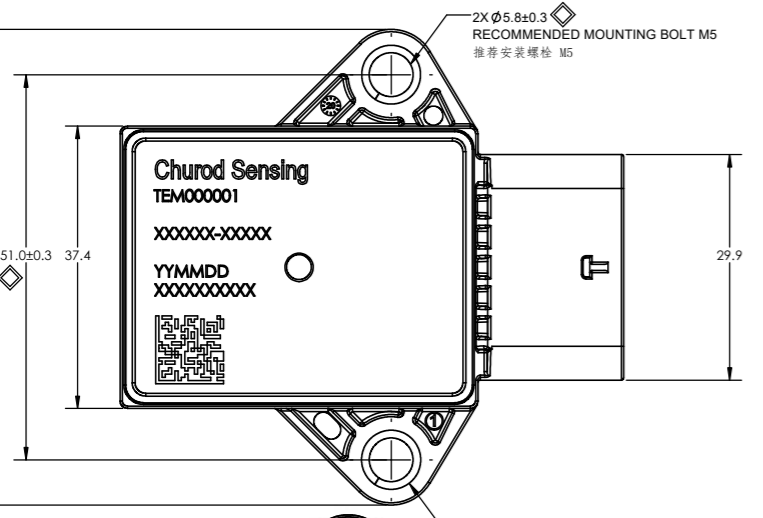
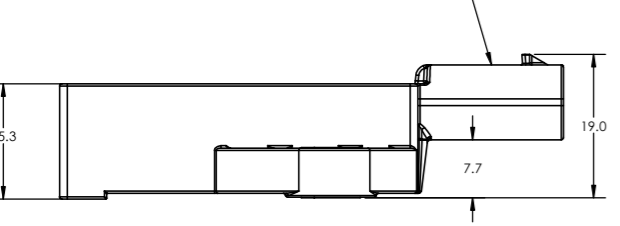

MOUNTING ORIENTATION AS ABOVE VIEW CAN MEET REQUIREMENT IN APPLICATION
 (+Z IS UPWARDLY PERPENDICULAR TO THE GROUND)
 安装方向如上图, 可以满足使用要求
 (+Z方向垂直于地平面向上)

