

## RSF10 SERIES

### HIGH LEVEL SWITCH FOR BOILING WATER



The RSF10 series drop float has been designed to eliminate problems associated with limescale build up around the pivot point of a conventional float switch. It is also suitable in more viscous liquids, that might affect the pivot action of a standard float type.

This particular series is primarily for applications where a high level condition has to be monitored.

The drop float actuator allows the switch housing and float pivots to be located above the surface of the liquid and provides a normally closed switch contact, opening as the liquid level rises.

They are manufactured in a range of materials, with a choice of gasket material, to suit most commonly used liquids.

Typical applications include wall kettles and hot vending machines.

Versions available with either flying leads or M12 circular connector.

There are cable sets available for use with M12 connector versions.

### Features

- Pivot out of liquid
- High level switch position
- Many WRAS (approved for use in hot & cold water) and NSF approved variants
- Many variants are UL recognised components File No. E171218
- Flying lead or M12 connector

## SPECIFICATIONS

### Technical

	RSF14	RSF18	RSF16
<b>Material</b>	Polypropylene WRAS approved	Polypropylene UL approved	Polyphenylene Sulphide (PPS)
<b>Colour</b>	Opaque	White	Grey
<b>Temp. Range</b>	°C -20/+100	-20/+100	-10/+120*
<b>Min. Fluid SG</b>	0.70	0.80	0.75
<b>Must Close Level (SG=1)</b>	39mm	39mm	33mm
<b>Must Open Level (SG=1)</b>	24mm	24mm	22mm

\* Maximum temperature requires ETFE cable to be specified.

## Electrical

		<b>25W (Y code)</b>	<b>100W (H code)</b>
<b>Contact Form</b>		N/C (N/O)	N/C (N/O)
<b>Switching Power Max</b>	VA	25	100
<b>Switching Voltage AC Max</b>	V	240	300
<b>Switching Voltage DC Max</b>	V	120	300
<b>Switching Current Max</b>	A	0.6	1

All ratings are for resistive load only.

## STANDARD PARTS

	<b>Material</b>	<b>Approvals</b>	<b>Max Power</b>	<b>Leadouts</b>	<b>Gasket</b>
<b>RSF14H100RF</b>	PP	WRAS & NSF	100VA	1 metre PVC 16/0.2	Nitrile
<b>RSF14Y050RF</b>	PP	WRAS & NSF	25VA	50 cm PVC 16/0.2	Nitrile
<b>RSF14Y100RF</b>	PP	WRAS & NSF	25VA	1 metre PVC 16/0.2	Nitrile
<b>RSF16H050TG</b>	PPS	WRAS, UL & NSF	100VA	50cm ETFE 19/0.2	Viton
<b>RSF16H100RF</b>	PPS	WRAS, UL & NSF	100VA	1 metre PVC 16/0.2	Nitrile
<b>RSF16Y050TG</b>	PPS	WRAS, UL & NSF	25VA	50cm ETFE 19/0.2	Viton
<b>RSF16Y100TG</b>	PPS	WRAS, UL & NSF	25VA	1 metre ETFE 19/0.2	Viton
<b>RSF16Y100RF</b>	PPS	WRAS, UL & NSF	25VA	1 metre PVC 16/0.2	Nitrile
<b>RSF18H100RF</b>	PP (UL)	UL	100VA	1 metre PVC 16/0.2	Nitrile
<b>RSF18Y100RF</b>	PP (UL)	UL	25VA	1 metre PVC 16/0.2	Nitrile
<b>RSF14HFP</b>	PP	WRAS & NSF	100VA	M12 connector	Nitrile
<b>RSF14YFP</b>	PP	WRAS & NSF	25VA	M12 connector	Nitrile
<b>RSF16HFP</b>	PPS	WRAS, UL & NSF	100VA	M12 connector	Nitrile
<b>RSF16YFP</b>	PPS	WRAS, UL & NSF	25VA	M12 connector	Nitrile
<b>RSF18HFP</b>	PP (UL)	UL	100VA	M12 connector	Nitrile
<b>RSF18YFP</b>	PP (UL)	UL	25VA	M12 connector	Nitrile

Custom versions can be made for particular applications. Please contact Sensata with your requirements.

## DIMENSIONS

All dimensions are in millimeters.

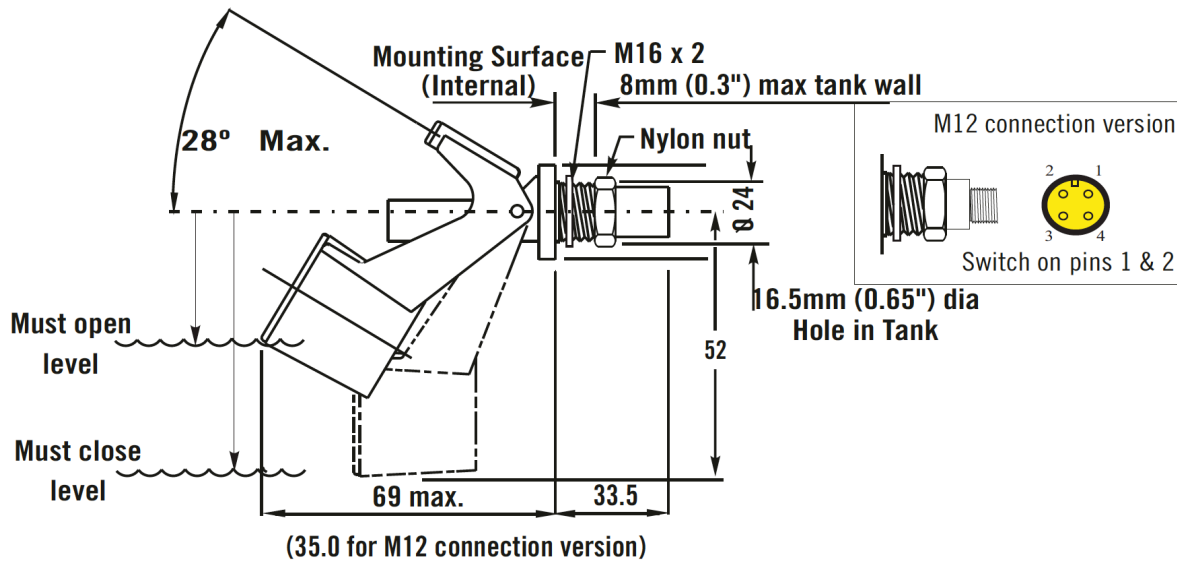

Datasheets provided by Sensata Technologies, Inc., its subsidiaries and/or affiliates ("Sensata") are solely intended to assist third parties ("Buyers") who are developing systems that incorporate Sensata products (also referred to herein as "components"). Buyer understands and agrees that Buyer remains responsible for using its independent analysis, valuation, and judgment in designing Buyer's systems and products. Sensata datasheets have been created using standard laboratory conditions and engineering practices. Sensata has not conducted any testing other than that specifically described in the published documentation for a particular datasheet. Sensata may make corrections, enhancements, improvements, and other changes to its datasheets or components without notice. Buyers are authorized to use Sensata datasheets with the Sensata component(s) identified in each particular datasheet. HOWEVER, NO OTHER LICENSE, EXPRESS OR IMPLIED, BY ESTOPPEL OR OTHERWISE TO ANY OTHER SENSATA INTELLECTUAL PROPERTY RIGHT, AND NO LICENSE TO ANY THIRD PARTY TECHNOLOGY OR INTELLECTUAL PROPERTY RIGHT, IS GRANTED HEREIN. SENSATA DATASHEETS ARE PROVIDED "AS IS". SENSATA MAKES NO WARRANTIES OR REPRESENTATIONS WITH REGARD TO THE DATASHEETS OR USE OF THE DATASHEETS, EXPRESS, IMPLIED, OR STATUTORY, INCLUDING ACCURACY OR COMPLETENESS. SENSATA DISCLAIMS ANY WARRANTY OF TITLE AND ANY IMPLIED WARRANTIES OF MERCHANTABILITY, FITNESS FOR A PARTICULAR PURPOSE, QUIET ENJOYMENT, QUIET POSSESSION, AND NON-INFRINGEMENT OF ANY THIRD PARTY INTELLECTUAL PROPERTY RIGHTS WITH REGARD TO SENSATA DATASHEETS OR USE THEREOF.

All products are sold subject to Sensata's terms and conditions of sale supplied at [www.sensata.com](http://www.sensata.com) SENSATA ASSUMES NO LIABILITY FOR APPLICATIONS ASSISTANCE OR THE DESIGN OF BUYERS' PRODUCTS. BUYER ACKNOWLEDGES AND AGREES THAT IT IS SOLELY RESPONSIBLE FOR COMPLIANCE WITH ALL LEGAL, REGULATORY, AND SAFETY-RELATED REQUIREMENTS CONCERNING ITS PRODUCTS, AND ANY USE OF SENSATA COMPONENTS IN ITS APPLICATIONS, NOTWITHSTANDING ANY APPLICATIONS-RELATED INFORMATION OR SUPPORT THAT MAY BE PROVIDED BY SENSATA.

Mailing Address: Sensata Technologies, Inc., 529 Pleasant Street, Attleboro, MA 02703, USA.

## CONTACT US

**Sensata Technologies**  
 Jan Tinbergenstraat 80  
 7559 SP Hengelo  
 The Netherlands  
 1-508-236-3800  
 +44 (0)1202 897969  
[cynergy3.enquiries@sensata.com](mailto:cynergy3.enquiries@sensata.com)