

MP1C SERIES

AUTOCLAVE LEVEL FLOAT SWITCH

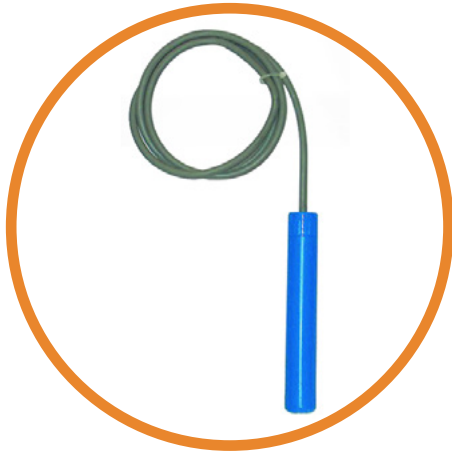

SPECIFICATIONS

Mechanical

		MP1C-3	MP1C-5
Contact Form		C/O	
Material		High Density Polyethylene	
Temp Range	°C	0 / +55	
	°F	+ 32 / +131	
Cable		3 metre	5 metre
Standard cable covering		PVC 3x1 A05 VVF Rf60	
Max. working pressure		10 bar	

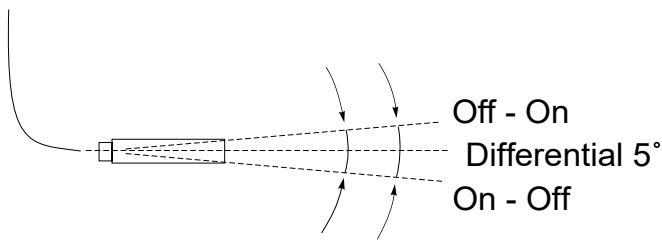

Minimum Cable Pivot
length 120mm

This float switch is designed specially to maintain the air cushion in autoclaves and is available in two different versions 1" or 1"1/4. diameter. Thanks to its small diameter it can be introduced into the tank through a coupling and mounted either horizontally or vertically (with counterweight). The level switch action point is determined by the cable length with the entry point (if horizontal) or to the application point (if vertical). When the tank water level rises , the switch gives the starting up command to the compressor contactor or to the compressed air valve, which then stops the pump with an auxiliary contact. When the water / air level stabilises at the desired position, the switch stops the compressor and starts the pump.

Features

- For compressor receivers or pressurised tanks
- Installation through G1" or G1"1/4
- Supplied with gland & counterweight
- Mount through side or top of tank

Electrical

Power Rating Max	3VA
Switching Voltage Max	60Vac
Switching Current Max. Resistive	0.25 A

It is necessary to use an auxiliary relay, when switching any significant load.

DIAMENSIONS

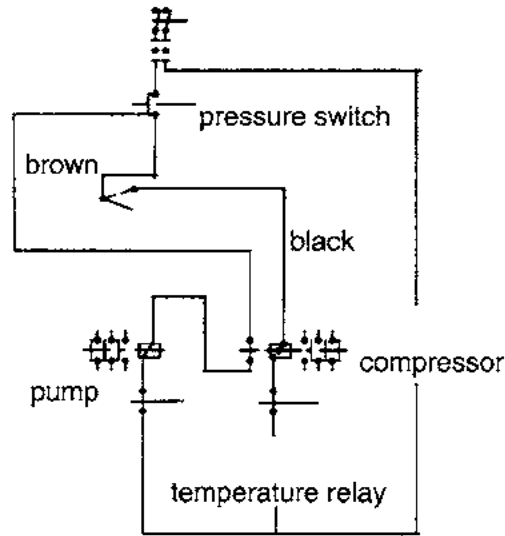

1" Ø 28,5 mm

1" 1/4 Ø 37,5 mm

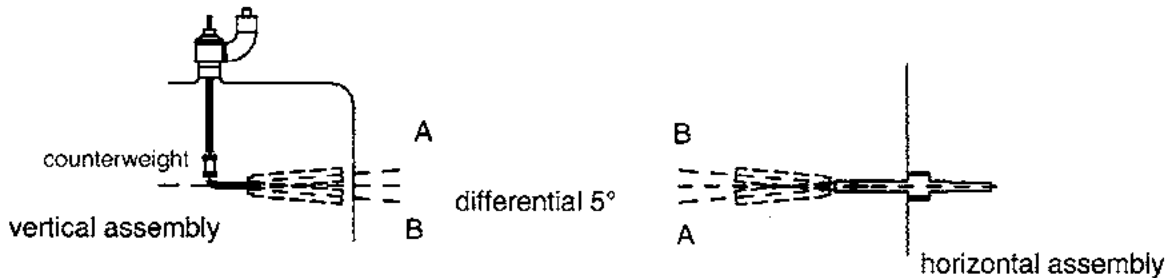
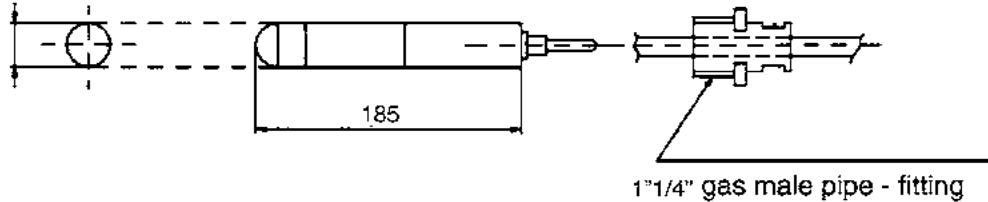

Datasheets provided by Sensata Technologies, Inc., its subsidiaries and/or affiliates ("Sensata") are solely intended to assist third parties ("Buyers") who are developing systems that incorporate Sensata products (also referred to herein as "components"). Buyer understands and agrees that Buyer remains responsible for using its independent analysis, valuation, and judgment in designing Buyer's systems and products. Sensata datasheets have been created using standard laboratory conditions and engineering practices. Sensata has not conducted any testing other than that specifically described in the published documentation for a particular datasheet. Sensata may make corrections, enhancements, improvements, and other changes to its datasheets or components without notice. Buyers are authorized to use Sensata datasheets with the Sensata component(s) identified in each particular datasheet. HOWEVER, NO OTHER LICENSE, EXPRESS OR IMPLIED, BY ESTOPPEL OR OTHERWISE TO ANY OTHER SENSATA INTELLECTUAL PROPERTY RIGHT, AND NO LICENSE TO ANY THIRD PARTY TECHNOLOGY OR INTELLECTUAL PROPERTY RIGHT, IS GRANTED HEREIN. SENSATA DATASHEETS ARE PROVIDED "AS IS". SENSATA MAKES NO WARRANTIES OR REPRESENTATIONS WITH REGARD TO THE DATASHEETS OR USE OF THE DATASHEETS, EXPRESS, IMPLIED, OR STATUTORY, INCLUDING ACCURACY OR COMPLETENESS. SENSATA DISCLAIMS ANY WARRANTY OF TITLE AND ANY IMPLIED WARRANTIES OF MERCHANTABILITY, FITNESS FOR A PARTICULAR PURPOSE, QUIET ENJOYMENT, QUIET POSSESSION, AND NON-INFRINGEMENT OF ANY THIRD PARTY INTELLECTUAL PROPERTY RIGHTS WITH REGARD TO SENSATA DATASHEETS OR USE THEREOF.

All products are sold subject to Sensata's terms and conditions of sale supplied at www.sensata.com. SENSATA ASSUMES NO LIABILITY FOR APPLICATIONS ASSISTANCE OR THE DESIGN OF BUYERS' PRODUCTS. BUYER ACKNOWLEDGES AND AGREES THAT IT IS SOLELY RESPONSIBLE FOR COMPLIANCE WITH ALL LEGAL, REGULATORY, AND SAFETY-RELATED REQUIREMENTS CONCERNING ITS PRODUCTS, AND ANY USE OF SENSATA COMPONENTS IN ITS APPLICATIONS, NOTWITHSTANDING ANY APPLICATIONS-RELATED INFORMATION OR SUPPORT THAT MAY BE PROVIDED BY SENSATA.

Mailing Address: Sensata Technologies, Inc., 529 Pleasant Street, Attleboro, MA 02703, USA

CONTACT US

Sensata Technologies
 Jan Tinbergenstraat 80
 7559 SP Hengelo
 The Netherlands
 1-508-236-3800
 +44 (0)1202 897969
cynergy3.enquiries@sensata.com