

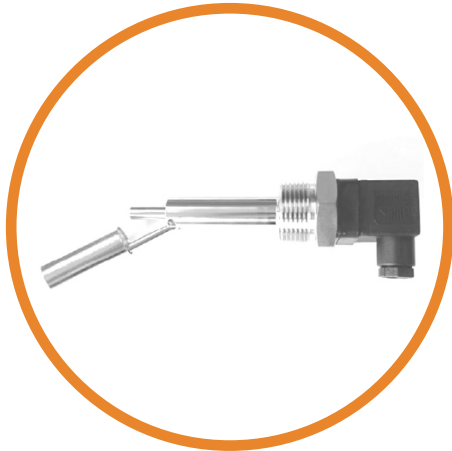

SSF216 SERIES

EXTRA-LONG REACH EXTERNAL MOUNT FLOAT SWITCH WITH 1" NPT MOUNT



The SSF216 float switches are externally mounted horizontal switches. This switch has an extra-long reach to provide a solution for extra thick tank walls or for mounting through welded-on 1" NPT bosses.

The 1" NPT thread enables the switches to be fitted through the wall of a tank from the outside, so does not require access to the inside of the tank.

The float switch can be fitted to achieve either N/O (make on rise) or N/C (make on fall) switching action by simply rotating the switch through 180°.

Features

- Longest reach for thick walled tanks and boss mounting
- Float material SS 316, stem material SS 304
- External mount via 1" NPT thread, so does not require access to the inside of the tank for fitting.
- N/O or N/C switching action

SPECIFICATIONS

Technical

Mounting Style	External
Mounting Thread	1" NPT
Float & Stem Material	316/304 grade SS
Maximum Temperature	120°C
Maximum Pressure	10 bar
Float SG	0.7
Minimum Fluid SG	0.8

Tightening torque should be adequate to ensure a good seal.

Electrical

Contact Form		N/O (N/C)
Switching Power Max	VA	50
Switching Voltage AC Max	V	300
Switching Voltage DC Max	V	300
Switching Current Max	A	0.5

All ratings are for resistive load only.

STANDARD PARTS

	Stem Material	Float Material	Connection
SSF216XPL	SS 304	SS 316	DIN43650

Custom versions can be made for particular applications. Please contact Sensata with your requirements.

DIMENSIONS

All dimensions are in millimeters.

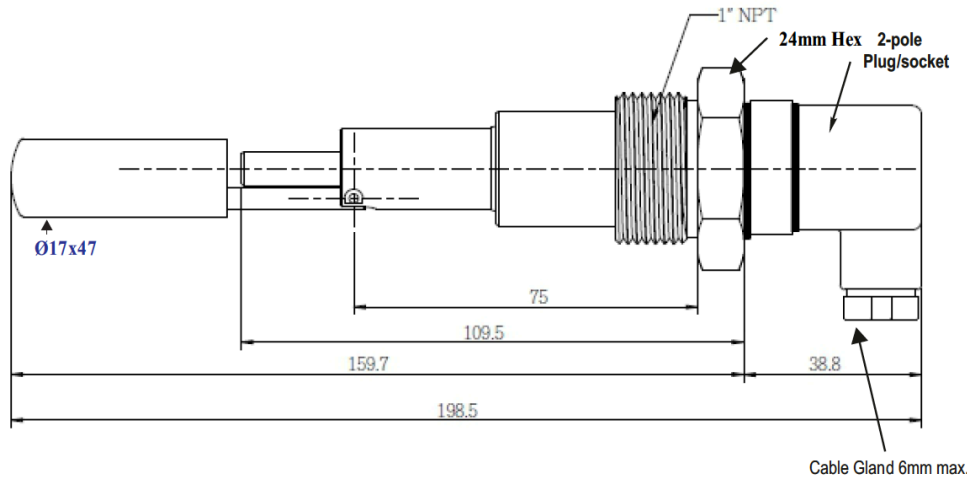

Datasheets provided by Sensata Technologies, Inc., its subsidiaries and/or affiliates ("Sensata") are solely intended to assist third parties ("Buyers") who are developing systems that incorporate Sensata products (also referred to herein as "components"). Buyer understands and agrees that Buyer remains responsible for using its independent analysis, valuation, and judgment in designing Buyer's systems and products. Sensata datasheets have been created using standard laboratory conditions and engineering practices. Sensata has not conducted any testing other than that specifically described in the published documentation for a particular datasheet. Sensata may make corrections, enhancements, improvements, and other changes to its datasheets or components without notice.

Buyers are authorized to use Sensata datasheets with the Sensata component(s) identified in each particular datasheet. HOWEVER, NO OTHER LICENSE, EXPRESS OR IMPLIED, BY ESTOPPEL OR OTHERWISE TO ANY OTHER SENSATA INTELLECTUAL PROPERTY RIGHT, AND NO LICENSE TO ANY THIRD PARTY TECHNOLOGY OR INTELLECTUAL PROPERTY RIGHT, IS GRANTED HEREIN. SENSATA DATASHEETS ARE PROVIDED "AS IS". SENSATA MAKES NO WARRANTIES OR REPRESENTATIONS WITH REGARD TO THE DATASHEETS OR USE OF THE DATASHEETS, EXPRESS, IMPLIED, OR STATUTORY, INCLUDING ACCURACY OR COMPLETENESS. SENSATA DISCLAIMS ANY WARRANTY OF TITLE AND ANY IMPLIED WARRANTIES OF MERCHANTABILITY, FITNESS FOR A PARTICULAR PURPOSE, QUIET ENJOYMENT, QUIET POSSESSION, AND NON-INFRINGEMENT OF ANY THIRD PARTY INTELLECTUAL PROPERTY RIGHTS WITH REGARD TO SENSATA DATASHEETS OR USE THEREOF.

All products are sold subject to Sensata's terms and conditions of sale supplied at www.sensata.com. SENSATA ASSUMES NO LIABILITY FOR APPLICATIONS ASSISTANCE OR THE DESIGN OF BUYERS' PRODUCTS. BUYER ACKNOWLEDGES AND AGREES THAT IT IS SOLELY RESPONSIBLE FOR COMPLIANCE WITH ALL LEGAL, REGULATORY, AND SAFETY-RELATED REQUIREMENTS CONCERNING ITS PRODUCTS, AND ANY USE OF SENSATA COMPONENTS IN ITS APPLICATIONS, NOTWITHSTANDING ANY APPLICATIONS-RELATED INFORMATION OR SUPPORT THAT MAY BE PROVIDED BY SENSATA.

Mailing Address: Sensata Technologies, Inc., 529 Pleasant Street, Attleboro, MA 02703, USA

CONTACT US

Sensata Technologies
Jan Tinbergenstraat 80
7559 SP Hengelo
The Netherlands
1-508-236-3800
+44 (0)1202 897969
cynergy3.enquiries@sensata.com