

SH-5 SERIES

1-1/2" 150LB ANSI FLANGE MOUNT SPDT SWITCH



The SH-5052 is a 1-1/2" - 150lb ANSI flange mount float operated level switch.

This design uses a pivoted float arm with a magnet on the inboard end. This magnet when moved by the rising float arm interacts with another magnet in the switch enclosure to give a snap action operation.

Features

- 1-1/2" - 150lb ANSI Flange
- SS 316L float material
- SS 304 other wetted parts material
- Available in direct switching version for use at up to 120°C
- Aluminium enclosure with screw on lid and cable gland

SPECIFICATIONS

Technical

Mounting Style	External via flange
Float Material	316L grade SS
Maximum Temperature	120°C
Maximum Pressure	10 bar
Float SG	0.55
Minimum Fluid SG	0.60
Flange Size	1-1/2"
Flange Rating	150lb
Other Wetted Parts	SS 304
Cable Entry	1/2" BSP
Enclosure Rating	IP65
Sealing Gasket	Not supplied

Electrical

Contact Form		SPDT
Switching Voltage AC Max	V	250
Switching Voltage DC Max	V	120
Switching Current Max	A	5

All electrical ratings are for resistive loads only.

STANDARD PARTS

	Material	Max Current	Temperature Range	Min SG	Mount
SH-5052	SS 316L/304	5	0 - 120°C	0.60	1-1/2"

Other flange types and pressure ratings may be possible. Please contact Sensata with your requirements.

DIMENSIONS

All dimensions are in millimeters.

SH-5052

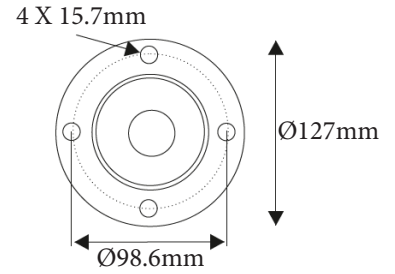
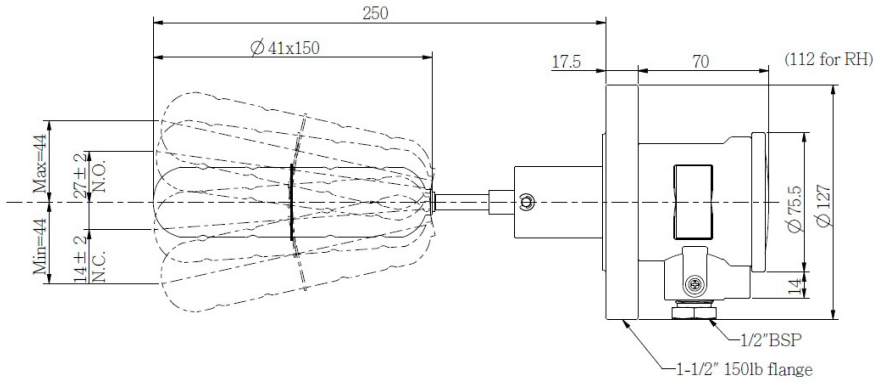

Datasheets provided by Sensata Technologies, Inc., its subsidiaries and/or affiliates ("Sensata") are solely intended to assist third parties ("Buyers") who are developing systems that incorporate Sensata products (also referred to herein as "components"). Buyer understands and agrees that Buyer remains responsible for using its independent analysis, valuation, and judgment in designing Buyer's systems and products. Sensata datasheets have been created using standard laboratory conditions and engineering practices. Sensata has not conducted any testing other than that specifically described in the published documentation for a particular datasheet. Sensata may make corrections, enhancements, improvements, and other changes to its datasheets or components without notice. Buyers are authorized to use Sensata datasheets with the Sensata component(s) identified in each particular datasheet. HOWEVER, NO OTHER LICENSE, EXPRESS OR IMPLIED, BY ESTOPPEL OR OTHERWISE TO ANY OTHER SENSATA INTELLECTUAL PROPERTY RIGHT, AND NO LICENSE TO ANY THIRD PARTY TECHNOLOGY OR INTELLECTUAL PROPERTY RIGHT, IS GRANTED HEREIN. SENSATA DATASHEETS ARE PROVIDED "AS IS". SENSATA MAKES NO WARRANTIES OR REPRESENTATIONS WITH REGARD TO THE DATASHEETS OR USE OF THE DATASHEETS, EXPRESS, IMPLIED, OR STATUTORY, INCLUDING ACCURACY OR COMPLETENESS. SENSATA DISCLAIMS ANY WARRANTY OF TITLE AND ANY IMPLIED WARRANTIES OF MERCHANTABILITY, FITNESS FOR A PARTICULAR PURPOSE, QUIET ENJOYMENT, QUIET POSSESSION, AND NON-INFRINGEMENT OF ANY THIRD PARTY INTELLECTUAL PROPERTY RIGHTS WITH REGARD TO SENSATA DATASHEETS OR USE THEREOF.

All products are sold subject to Sensata's terms and conditions of sale supplied at www.sensata.com. SENSATA ASSUMES NO LIABILITY FOR APPLICATIONS ASSISTANCE OR THE DESIGN OF BUYERS' PRODUCTS. BUYER ACKNOWLEDGES AND AGREES THAT IT IS SOLELY RESPONSIBLE FOR COMPLIANCE WITH ALL LEGAL, REGULATORY, AND SAFETY-RELATED REQUIREMENTS CONCERNING ITS PRODUCTS, AND ANY USE OF SENSATA COMPONENTS IN ITS APPLICATIONS, NOTWITHSTANDING ANY APPLICATIONS-RELATED INFORMATION OR SUPPORT THAT MAY BE PROVIDED BY SENSATA.

Mailing Address: Sensata Technologies, Inc., 529 Pleasant Street, Attleboro, MA 02703, USA

CONTACT US

Sensata Technologies
 Jan Tinbergenstraat 80
 7559 SP Hengelo
 The Netherlands
 1-508-236-3800
 +44 (0)1202 897969
cynergy3.enquiries@sensata.com