

## SM20

### LEVEL CONTROLLER OR HIGH POWER INTERFACE MODULE



The SM20 is a versatile level control or interface module that can also be used in many other process control applications.

One level switch can be connected for an alarm or two level switches to start and stop a submersible pump or a solenoid valve for emptying/filling function

It works with all kind of level switches, including conductive probes, as well as pressure switches or other limit switches.

The module can be used as a dry-running protection, with a pressure switch or filling level control switch, to start and stop a pump.

Power supply 240/415 Vac.

Two out-puts:

Main output SPCO 20(8) Ampere 250V

Secondary output SPCO 10(4) Ampere 250V automatic/manual switch

LED indicators for: power supply, low level and output on.

## SPECIFICATIONS

### Technical

<b>Supply Voltage</b>	V	240 or 415ac
<b>Sensor Voltage</b>	V	12Vac
<b>Sensor Input</b>	switch contacts or conductive probes	

### Output Ratings

			Output 1	Output 2
<b>Contact Form</b>			SPCO	SPCO
<b>Switching Power Max ac</b>		VA	1500	750
<b>Switching Power Max dc</b>		W	560	not approved
<b>Switching Voltage AC Max</b>		V	250	250
<b>Switching Voltage DC Max</b>		V	28	not approved
<b>Switching Current Max Resistive</b>	(n/o contact)	A	20	10
	(n/c contact)	A	10	10
<b>Switching Current Max Inductive</b>		A	8	4

### Features

- Primary output can directly control motors up to 2HP cosF 0.4-0.5 single phase
- 2 SPCO relay outputs
- 12Vac sensor voltage
- 1, 2 or 3 sensor inputs
- 240 or 415Vac supply
- DIN rail mounting

## STANDARD PARTS

Standard Parts	Inputs	Outputs
SM20	1, 2 or 3	2

Other versions can be made for particular applications. Please contact Sensata with your requirements.

## DIMENSIONS

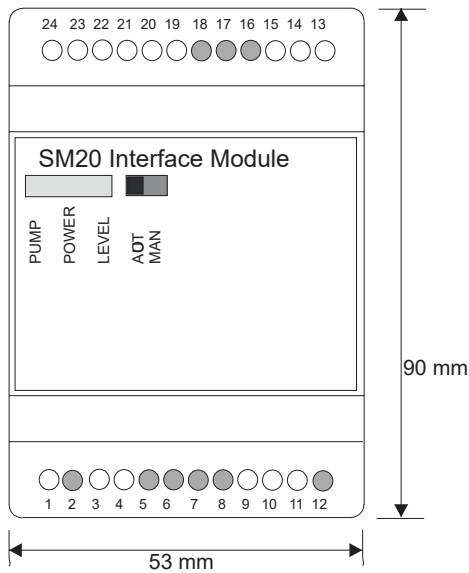

1	Supply Neutral
3	Supply Live 240Vac
4	Supply Live 415Vac
9	Output 1 nc contact
10	Output 1 no contact
11	Output 1 common
13	Output 2 no contact
14	Output 2 common
15	Output 2 nc contact
19-20	Low voltage input sensor
21-22	Sensor common input
23	Sensor minimum level
24	Sensor maximum level

Low voltage input 19-20 for pressure switch with contacts closed at minimum pressure or level switch with contacts closed when level low.  
**NB These terminals must be bridged if no sensor is connected.**

## LEVEL CONTROLLER OR HIGH POWER INTERFACE MODULE

The SM20 can be used for many process control functions, including:

- Dry running control with 2 level switches
- Dry running control with 1 level switch
- Dry running control with conductive probes
- Pump control by pressure switch
- Pump control by level switch
- Automatic/manual control selector
- "No water" alarm or secondary control output

### Troubleshooting

Pump does not start, green LED off	No power to module
Pump does not start, yellow LED on	Check connections 9-10-11 for pump supply
Pump does not start, yellow LED off	Check link between 19-20. Check pressure or level switch, if fitted. Check system has not already reached maximum pressure or level
Pump does not start, red LED on	No water in supply tank. Check maximum level switch is correctly installed. Check terminals 21-22-23-24
Pump does no stop	Check the Auto/Man selector. Check that pressure or level switch, on 19-20, functions correctly.

### Example: Rainwater supply

Filling a vented roof tank from a rainwater tank.  
 The pump will operate when the roof tank level is not at max level and the water in the rainwater tank is above the low level.  
 The secondary output relay will operate, if the level in the rainwater tank drops to the low level, and opens a solenoid valve to supply water from the mains water supply, which will remain operated until the rainwater tank fills to the high level.  
 The illustration is only for 220/240Vac supply, which is connected to terminals 0 (neutral) and 3 (live).

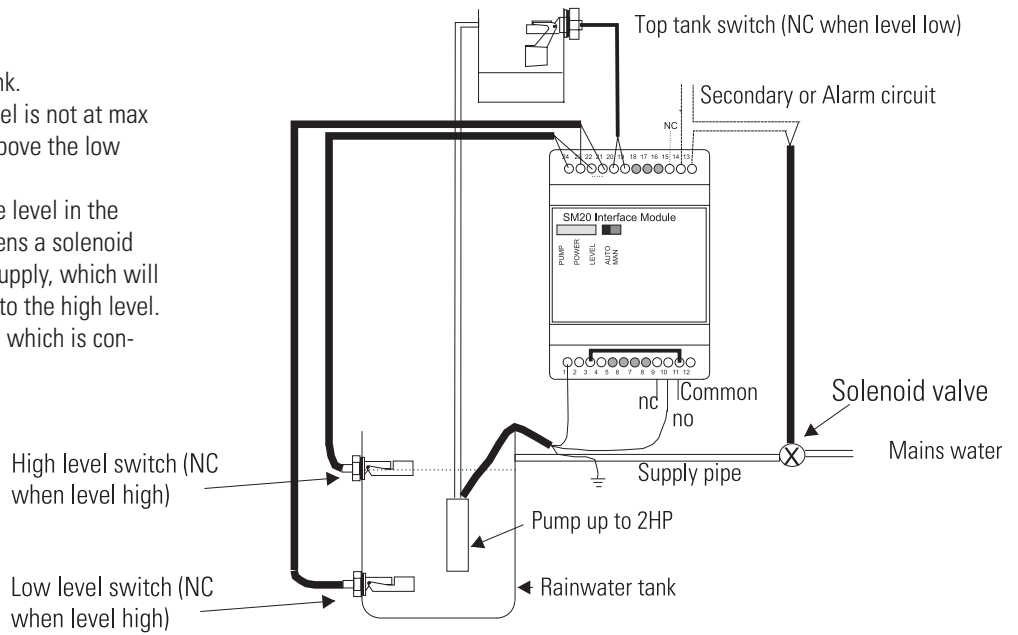

### Example: Sump pump to drain

This will pump out a sump from a high level down to a low level.  
 The pump will be started when the level in the sump reaches the high level and will continue to pump until the level falls to the low level.  
 The pump can also be operated manually using the switch on the module.  
 The illustration is only for 220/240Vac supply, which is connected to terminals 0 (neutral) and 3 (live).

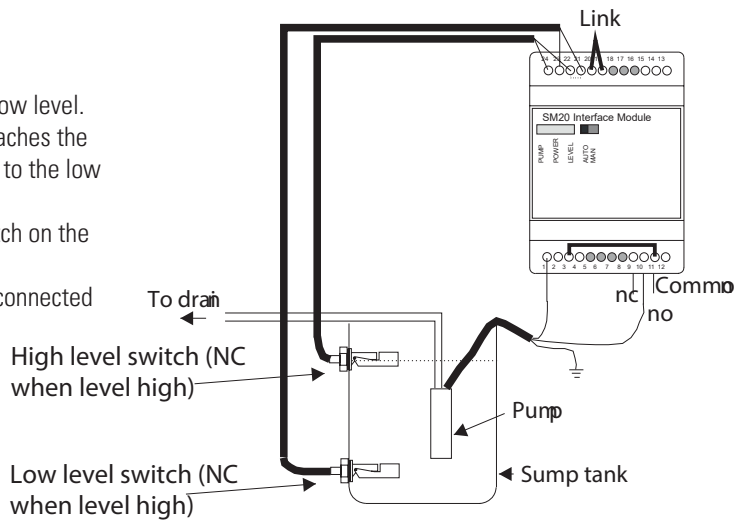

NB The diagrams shown above are simplified illustrations of how the module may be used and do not include any necessary safety devices, such as fuses or thermal cutouts, or statutory requirements for installation of such electrical equipment.

Datasheets provided by Sensata Technologies, Inc., its subsidiaries and/or affiliates ("Sensata") are solely intended to assist third parties ("Buyers") who are developing systems that incorporate Sensata products (also referred to herein as "components"). Buyer understands and agrees that Buyer remains responsible for using its independent analysis, valuation, and judgment in designing Buyer's systems and products. Sensata datasheets have been created using standard laboratory conditions and engineering practices. Sensata has not conducted any testing other than that specifically described in the published documentation for a particular datasheet. Sensata may make corrections, enhancements, improvements, and other changes to its datasheets or components without notice. Buyers are authorized to use Sensata datasheets with the Sensata component(s) identified in each particular datasheet. HOWEVER, NO OTHER LICENSE, EXPRESS OR IMPLIED, BY ESTOPPEL OR OTHERWISE TO ANY OTHER SENSATA INTELLECTUAL PROPERTY RIGHT, AND NO LICENSE TO ANY THIRD PARTY TECHNOLOGY OR INTELLECTUAL PROPERTY RIGHT, IS GRANTED HEREIN. SENSATA DATASHEETS ARE PROVIDED "AS IS". SENSATA MAKES NO WARRANTIES OR REPRESENTATIONS WITH REGARD TO THE DATASHEETS OR USE OF THE DATASHEETS, EXPRESS, IMPLIED, OR STATUTORY, INCLUDING ACCURACY OR COMPLETENESS. SENSATA DISCLAIMS ANY WARRANTY OF TITLE AND ANY IMPLIED WARRANTIES OF MERCHANTABILITY, FITNESS FOR A PARTICULAR PURPOSE, QUIET ENJOYMENT, QUIET POSSESSION, AND NON-INFRINGEMENT OF ANY THIRD PARTY INTELLECTUAL PROPERTY RIGHTS WITH REGARD TO SENSATA DATASHEETS OR USE THEREOF.

All products are sold subject to Sensata's terms and conditions of sale supplied at [www.sensata.com](http://www.sensata.com). SENSATA ASSUMES NO LIABILITY FOR APPLICATIONS ASSISTANCE OR THE DESIGN OF BUYERS' PRODUCTS. BUYER ACKNOWLEDGES AND AGREES THAT IT IS SOLELY RESPONSIBLE FOR COMPLIANCE WITH ALL LEGAL, REGULATORY, AND SAFETY-RELATED REQUIREMENTS CONCERNING ITS PRODUCTS, AND ANY USE OF SENSATA COMPONENTS IN ITS APPLICATIONS, NOTWITHSTANDING ANY APPLICATIONS-RELATED INFORMATION OR SUPPORT THAT MAY BE PROVIDED BY SENSATA.

Mailing Address: Sensata Technologies, Inc., 529 Pleasant Street, Attleboro, MA 02703, USA

### CONTACT US

**Sensata Technologies**  
 Jan Tinbergenstraat 80  
 7559 SP Hengelo  
 The Netherlands  
 1-508-236-3800  
 +44 (0)1202 897969  
[cynergy3.enquiries@sensata.com](mailto:cynergy3.enquiries@sensata.com)