

## SSH66TU SERIES

SHORT SWITCH FOR INTERNAL OR EXTERNAL MOUNTING VIA 1/2"NPT THREAD



The SSH66TU series are horizontal float switches, with short floats, which offer the choice of internal or external fixing 1/2"NPT threads.

The float is manufactured from High Grade 316 stainless steel and the stem is manufactured from 304 stainless steel.

The switch action may be reversed by mounting the device with the float able to move upwards away from the body, instead of the more normal downwards direction.

### Features

- Internal or External mount
- Short float version
- Stainless steel SS 304/316
- Operating temperature to 120°C
- N/O or N/C switch action

## SPECIFICATIONS

### Technical

<b>Mounting Style</b>	Internal/External
<b>Mounting Thread</b>	1/2"NPT
<b>Float &amp; Stem Material</b>	316/304 grade SS
<b>Maximum Temperature</b>	120°C
<b>Maximum Pressure</b>	10 bar
<b>Float SG</b>	0.7
<b>Minimum Fluid SG</b>	0.75
<b>Cable Length - Standard</b>	100cm
<b>Cable Size</b>	17/0.10 - AWG22
<b>Cable Conductor Material</b>	Tinned copper
<b>Cable Sheath Material</b>	XLPE
<b>Cable Temperature Rating</b>	125°C
<b>Sealing Gasket</b>	Not supplied
<b>Tightening Torque for Fixing Nut</b>	2.0kg/cm

### Electrical

<b>Contact Form</b>		N/O (N/C)
<b>Switching Power Max</b>	VA	1
<b>Switching Voltage AC Max</b>	V	24
<b>Switching Voltage DC Max</b>	V	24
<b>Switching Current Max</b>	A	0.1

All ratings are for resistive load only.

## STANDARD PARTS

	Material	Max Power	Leadouts	Gasket
<b>SSH66TU12N100S</b>	316/304 SS	1VA	100cm XLPE	N/A

Custom versions can be made for particular applications. Please contact Sensata with your requirements.

## DIMENSIONS

All dimensions are in millimeters.

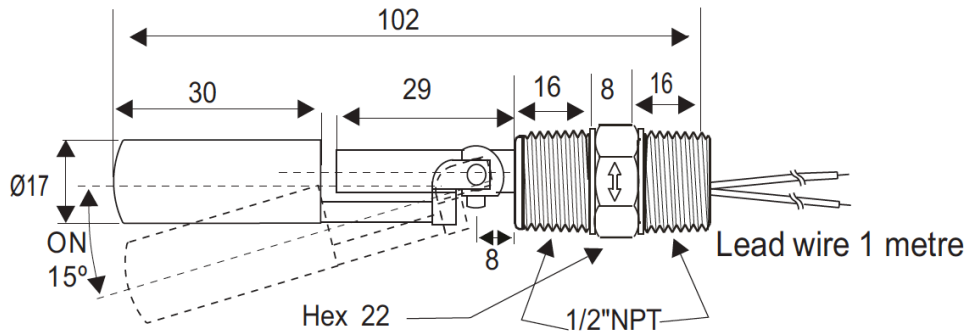

Datasheets provided by Sensata Technologies, Inc., its subsidiaries and/or affiliates ("Sensata") are solely intended to assist third parties ("Buyers") who are developing systems that incorporate Sensata products (also referred to herein as "components"). Buyer understands and agrees that Buyer remains responsible for using its independent analysis, valuation, and judgment in designing Buyer's systems and products. Sensata datasheets have been created using standard laboratory conditions and engineering practices. Sensata has not conducted any testing other than that specifically described in the published documentation for a particular datasheet. Sensata may make corrections, enhancements, improvements, and other changes to its datasheets or components without notice. Buyers are authorized to use Sensata datasheets with the Sensata component(s) identified in each particular datasheet. HOWEVER, NO OTHER LICENSE, EXPRESS OR IMPLIED, BY ESTOPPEL OR OTHERWISE TO ANY OTHER SENSATA INTELLECTUAL PROPERTY RIGHT, AND NO LICENSE TO ANY THIRD PARTY TECHNOLOGY OR INTELLECTUAL PROPERTY RIGHT, IS GRANTED HEREIN. SENSATA DATASHEETS ARE PROVIDED "AS IS". SENSATA MAKES NO WARRANTIES OR REPRESENTATIONS WITH REGARD TO THE DATASHEETS OR USE OF THE DATASHEETS, EXPRESS, IMPLIED, OR STATUTORY, INCLUDING ACCURACY OR COMPLETENESS. SENSATA DISCLAIMS ANY WARRANTY OF TITLE AND ANY IMPLIED WARRANTIES OF MERCHANTABILITY, FITNESS FOR A PARTICULAR PURPOSE, QUIET ENJOYMENT, QUIET POSSESSION, AND NON-INFRINGEMENT OF ANY THIRD PARTY INTELLECTUAL PROPERTY RIGHTS WITH REGARD TO SENSATA DATASHEETS OR USE THEREOF.

All products are sold subject to Sensata's terms and conditions of sale supplied at [www.sensata.com](http://www.sensata.com). SENSATA ASSUMES NO LIABILITY FOR APPLICATIONS ASSISTANCE OR THE DESIGN OF BUYERS' PRODUCTS. BUYER ACKNOWLEDGES AND AGREES THAT IT IS SOLELY RESPONSIBLE FOR COMPLIANCE WITH ALL LEGAL, REGULATORY, AND SAFETY-RELATED REQUIREMENTS CONCERNING ITS PRODUCTS, AND ANY USE OF SENSATA COMPONENTS IN ITS APPLICATIONS, NOTWITHSTANDING ANY APPLICATIONS-RELATED INFORMATION OR SUPPORT THAT MAY BE PROVIDED BY SENSATA.

Mailing Address: Sensata Technologies, Inc., 529 Pleasant Street, Attleboro, MA 02703, USA

## CONTACT US

**Sensata Technologies**  
 Jan Tinbergenstraat 80  
 7559 SP Hengelo  
 The Netherlands  
 1-508-236-3800  
 +44 (0)1202 897969  
[cynergy3.enquiries@sensata.com](mailto:cynergy3.enquiries@sensata.com)