

SSF50 SERIES

COMPACT FLOAT SWITCH WITH INTEGRAL SLOSH GUARD & OPTIONAL CHECK FACILITY



The SSF50 series is a compact vertical float switch with an integral acrylic slosh guard to reduce inadvertent operation in turbulent fluids. The unit can be mounted to a vertical surface or via a U-bolt (not supplied) using the integrated mounting bracket.

The metal components are manufactured from a combination of 316 and 304 grade stainless steels.

The switch action may be reversed by removing the float, inverting and then refitting it to the central stem (tools required).

The unit can be supplied complete with an integral test facility whereby the float can be manually raised to check the operation of the switch.

Features

SPECIFICATIONS

Technical

Mounting Style	Mounting bracket included
Cable Size	17/0.16 - AWG22
Float & Stem Material	316 and 304 grade SS
Cable Sheath Material	FEP
Maximum Pressure	Ambient
Float SG	0.7
Cable Length - Standard	100cm
Cable Entry Rating	designed to IP67
SLOSH Shield Material	Acrylic 60mm dia x 4mm
Total Weight (-C version)	335g
Maximum Temperature	80°C
Minimum Fluid SG	0.8

Electrical

Contact Form		N/O (N/C)
Switching Power Max	VA	50
Switching Voltage AC Max	V	240
Switching Voltage DC Max	V	200
Switching Current Max	A	0.5

All ratings are for resistive load only.

STANDARD PARTS

	Description
SSF50X100X	
SSF50X100X-C	

Custom versions can be made for particular applications. Please contact Sensata with your requirements.

DIMENSIONS

All dimensions are in millimeters.

SSF50X100X-C

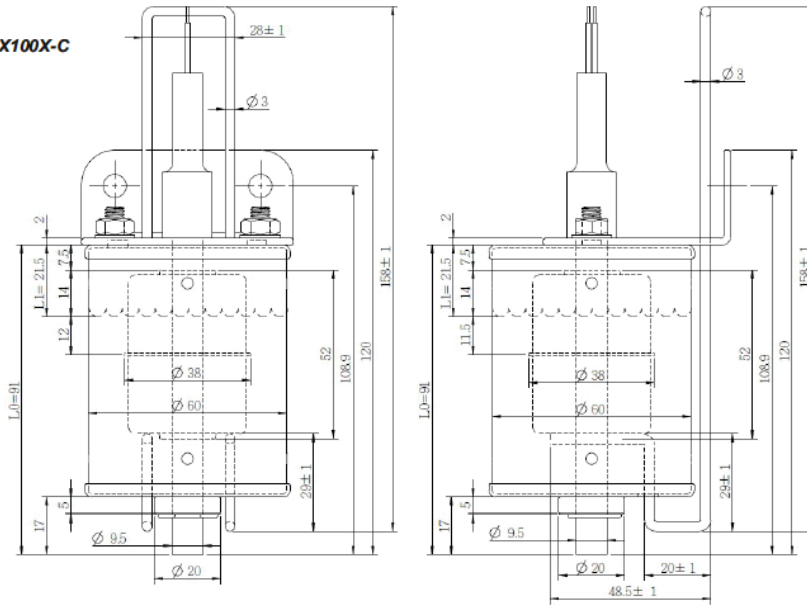

SSF50X100X

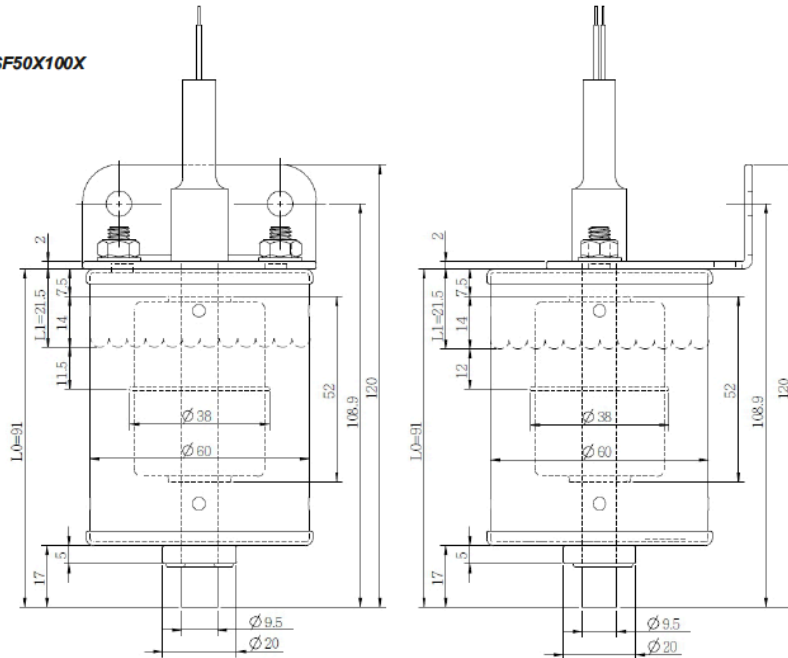

Datasheets provided by Sensata Technologies, Inc., its subsidiaries and/or affiliates ("Sensata") are solely intended to assist third parties ("Buyers") who are developing systems that incorporate Sensata products (also referred to herein as "components"). Buyer understands and agrees that Buyer remains responsible for using its independent analysis, valuation, and judgment in designing Buyer's systems and products. Sensata datasheets have been created using standard laboratory conditions and engineering practices. Sensata has not conducted any testing other than that specifically described in the published documentation for a particular datasheet. Sensata may make corrections, enhancements, improvements, and other changes to its datasheets or components without notice. Buyers are authorized to use Sensata datasheets with the Sensata component(s) identified in each particular datasheet. HOWEVER, NO OTHER LICENSE, EXPRESS OR IMPLIED, BY ESTOPPEL OR OTHERWISE TO ANY OTHER SENSATA INTELLECTUAL PROPERTY RIGHT, AND NO LICENSE TO ANY THIRD PARTY TECHNOLOGY OR INTELLECTUAL PROPERTY RIGHT, IS GRANTED HEREIN. SENSATA DATASHEETS ARE PROVIDED "AS IS". SENSATA MAKES NO WARRANTIES OR REPRESENTATIONS WITH REGARD TO THE DATASHEETS OR USE OF THE DATASHEETS, EXPRESS, IMPLIED, OR STATUTORY, INCLUDING ACCURACY OR COMPLETENESS. SENSATA DISCLAIMS ANY WARRANTY OF TITLE AND ANY IMPLIED WARRANTIES OF MERCHANTABILITY, FITNESS FOR A PARTICULAR PURPOSE, QUIET ENJOYMENT, QUIET POSSESSION, AND NON-INFRINGEMENT OF ANY THIRD PARTY INTELLECTUAL PROPERTY RIGHTS WITH REGARD TO SENSATA DATASHEETS OR USE THEREOF.

All products are sold subject to Sensata's terms and conditions of sale supplied at www.sensata.com. SENSATA ASSUMES NO LIABILITY FOR APPLICATIONS ASSISTANCE OR THE DESIGN OF BUYERS' PRODUCTS. BUYER ACKNOWLEDGES AND AGREES THAT IT IS SOLELY RESPONSIBLE FOR COMPLIANCE WITH ALL LEGAL, REGULATORY, AND SAFETY-RELATED REQUIREMENTS CONCERNING ITS PRODUCTS, AND ANY USE OF SENSATA COMPONENTS IN ITS APPLICATIONS, NOTWITHSTANDING ANY APPLICATIONS-RELATED INFORMATION OR SUPPORT THAT MAY BE PROVIDED BY SENSATA.

Mailing Address: Sensata Technologies, Inc., 529 Pleasant Street, Attleboro, MA 02703, USA

CONTACT US

Sensata Technologies
 Jan Tinbergenstraat 80
 7559 SP Hengelo
 The Netherlands
 1-508-236-3800
 +44 (0)1202 897969
cynergy3.enquiries@sensata.com