



| TSF40 SERIES

COMPACT INTERNAL MOUNT WITH TEMPERATURE SENSING

The TSF40 series is a compact internal fitting device, with a high specification thermistor so capable of sensing both liquid level and temperature. Mounting of this series requires access to the inside of the tank.



Typical applications include vending machines, commercial washing machines and evaporator units.

They are manufactured in a variety of materials with a choice of gasket materials, to suit most commonly used liquids.

The switch action may be reversed by rotating the device through 180°.

Available with flying lead connection.

Features

- Compact design with temperature sensing
- Available in Nylon, Polypropylene or PPS
- 25VA & 100VA versions
- WRAS Approved versions

● SPECIFICATIONS

Technical

	TSF43	TSF44	TSF48	TSF46
Material	Nylon	Polypropylene WRAS approved	Polypropylene	Polyphenylene Sulphide (PPS)
Colour	Black	Opaque	White	Grey
Temp. Range	°C	-20/+75	-20/+100	-10/+120*
	°F	-4/+167	-4/+212	+14/+248*
Min. Fluid SG	0.85	0.85	0.85	0.85
Must Close Level (SG=1)	7mm	8mm	8mm	9mm
Must Open Level (SG=1)	20mm	20mm	20mm	24mm

*Maximum temperature requires ETFE cable to be specified.

Electrical

		25W (Y code)	100W (H code)
Contact Form		N/O (N/C)	N/O (N/C)
Switching Power Max	VA	25	100
Switching Voltage AC Max	V	240	300
Switching Voltage DC Max	V	120	300
Switching Current Max	A	0.6	1

All ratings are for resistive load only.

Thermistor

Nominal Temperature Resistance	10k Ohm at 25°C
Resistance Tolerance	+/- 1%(25°C) to +/-4.3%(120°C)
Operating Temperature Range	-20°C to +120°C
Temperature Sensing Accuracy	+/-0.2°C (0°C to +70°C)
Beta Value	3892K (0/50°C)
Response Time	<1 sec
Dissipation Constant	0.75mW/K

STANDARD PARTS

	Material	Temperature	Max Power	Leadouts	Gasket	Approvals
TSF43H100DF	Nylon	-20°C to +75°C	100VA	100cm PVC 16/0.2	Nitrile	WRAS
TSF43Y100DF	Nylon	-20°C to +75°C	25VA	100cm PVC 16/0.2	Nitrile	WRAS
TSF44H100DF	PP	-20°C to +100°C	100VA	100cm PVC 16/0.2	Nitrile	WRAS
TSF44Y100DF	PP	-20°C to +100°C	25VA	100cm PVC 16/0.2	Nitrile	WRAS
TSF46H050TG	PPS	-10°C to +120°C	100VA	50cm ETFE 19/0.2	Viton	WRAS
TSF46H100DF	PPS	-10°C to +100°C	100VA	100cm PVC 16/0.2	Nitrile	WRAS
TSF46Y050TG	PPS	-10°C to +120°C	25VA	50cm ETFE 19/0.2	Viton	WRAS
TSF46Y100DF	PPS	-10°C to +105°C	25VA	100cm PVC 16/0.2	Nitrile	WRAS
TSF48H100DF	PP (UL)	-20°C to +100°C	100VA	100cm PVC 16/0.2	Nitrile	
TSF48Y100DF	PP (UL)	-20°C to +100°C	100VA	100cm PVC 16/0.2	Nitrile	

Custom versions can be made for particular applications. Please contact Sensata with your requirements.

DIMENSIONS

All dimensions are in millimeters.

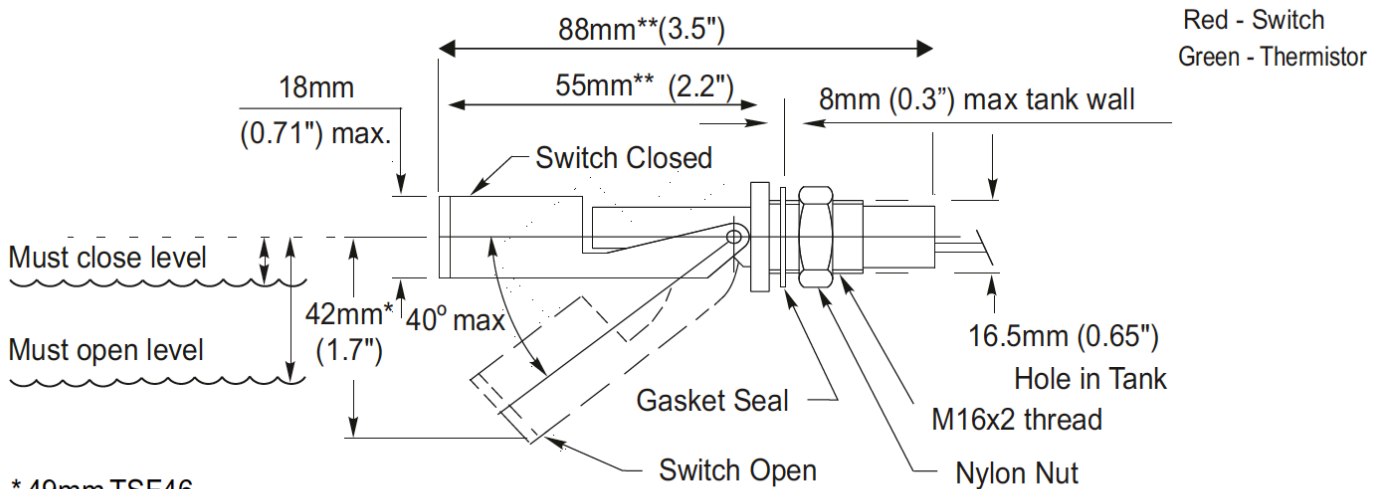

* 49mm TSF46

** Add 10mm to dims, TSF46

Datasheets provided by Sensata Technologies, Inc., its subsidiaries and/or affiliates ("Sensata") are solely intended to assist third parties ("Buyers") who are developing systems that incorporate Sensata products (also referred to herein as "components"). Buyer understands and agrees that Buyer remains responsible for using its independent analysis, valuation, and judgment in designing Buyer's systems and products. Sensata datasheets have been created using standard laboratory conditions and engineering practices. Sensata has not conducted any testing other than that specifically described in the published documentation for a particular datasheet. Sensata may make corrections, enhancements, improvements, and other changes to its datasheets or components without notice. Buyers are authorized to use Sensata datasheets with the Sensata component(s) identified in each particular datasheet. HOWEVER, NO OTHER LICENSE, EXPRESS OR IMPLIED, BY ESTOPPEL OR OTHERWISE TO ANY OTHER SENSATA INTELLECTUAL PROPERTY RIGHT, AND NO LICENSE TO ANY THIRD PARTY TECHNOLOGY OR INTELLECTUAL PROPERTY RIGHT, IS GRANTED HEREIN. SENSATA DATASHEETS ARE PROVIDED "AS IS". SENSATA MAKES NO WARRANTIES OR REPRESENTATIONS WITH REGARD TO THE DATASHEETS OR USE OF THE DATASHEETS, EXPRESS, IMPLIED, OR STATUTORY, INCLUDING ACCURACY OR COMPLETENESS. SENSATA DISCLAIMS ANY WARRANTY OF TITLE AND ANY IMPLIED WARRANTIES OF MERCHANTABILITY, FITNESS FOR A PARTICULAR PURPOSE, QUIET ENJOYMENT, QUIET POSSESSION, AND NON-INFRINGEMENT OF ANY THIRD PARTY INTELLECTUAL PROPERTY RIGHTS WITH REGARD TO SENSATA DATASHEETS OR USE THEREOF.

All products are sold subject to Sensata's terms and conditions of sale supplied at www.sensata.com. SENSATA ASSUMES NO LIABILITY FOR APPLICATIONS ASSISTANCE OR THE DESIGN OF BUYERS' PRODUCTS. BUYER ACKNOWLEDGES AND AGREES THAT IT IS SOLELY RESPONSIBLE FOR COMPLIANCE WITH ALL LEGAL, REGULATORY, AND SAFETY-RELATED REQUIREMENTS CONCERNING ITS PRODUCTS, AND ANY USE OF SENSATA COMPONENTS IN ITS APPLICATIONS, NOTWITHSTANDING ANY APPLICATIONS-RELATED INFORMATION OR SUPPORT THAT MAY BE PROVIDED BY SENSATA.

Mailing Address: Sensata Technologies, Inc., 529 Pleasant Street, Attleboro, MA 02703, USA

CONTACT US

Sensata Technologies
Jan Tinbergenstraat 80
7559 SP Hengelo
The Netherlands
1-508-236-3800
+44 (0)1202 897969
cynergy3.enquiries@sensata.com