

FSH10AR

FLOW SWITCH FOR G1", G2", G3" OR G4" PIPES



SPECIFICATIONS

Technical

Screw mount Material	Brass		
Enclosure material	Polyamide		
Enclosure rating	IP54		
Start up flow rate	Q. min	l/min	20
Max Pressure	P max	bar	10
Max Temperature	T max	°C	100
Pipe connections		BSP	1"
Pump stop delay range		sec	0 - 10

The FSH10AR can be used to control a pump or some other equipment or process via a relay output. If used in a pumped system, the device has to be fitted in the pipe after the pump.

It could be for controlling a circulating or centrifugal electric pump that is providing increased pressure or flow within water systems with storage tanks.

The FSH10 switches the output, once the flow rate through the pipe exceeds 20 l/min. When used to activate a pump, it can give an increased flow and pressure, dependant on the pump capacity.

The turn off time delay is adjustable between 0 and 10 seconds.

A flow of less than 20 l/min, whether due to a lack of supply (e.g. tank empty) or to a decrease in demand (e.g. tap closing), will turn the output off again.

Features

- General purpose switch for loads of up to 4A inductive
- 20 l/min turn on flow rate
- Automatic shut down on flow stop
- Adjustable time delay from 0 to 10 seconds for pump stop
- 1" BSP pipe connections for mounting

Electrical

Supply Voltage	Vac	24 or 240
Switching Voltage Max	Vac	250
Switching Power Max	kW	1
Switching Current Max	A	10 for resistive load 4A for motor load

INSTALLATION

The flow switch is designed to be used in a horizontal pipe with the switch mounted through a side entry. Pipe connection is G1" (1" BSP). The device relies on the flow of liquid working in opposition to the spring loaded paddle to operate the relay.

The liquid flow moves paddle within the pipe, when the flow increases beyond the minimum specified level. A magnet mounted on the head of the paddle closes a magnetic switch in the control circuit, so causing this to operate the output relay.

The output relay will remain energised for the time delay set, if the flow drops below the specified level and the paddle has returned to the rest position, and will then be de-energised.

The output relay will be energised for the time delay set, if the unit is disconnected then reconnected to the supply voltage or the test button is pushed.

The unit can operate on a supply voltage of either 24 or 240ac.

The output is a SPCO electromechanical relay with contacts rated to 10(4)A 250Vac.

There is a spare terminal connected to the 240Vac supply that can be used, if a 240Vac supply is being used, to link to the common contact of the relay, if a 240Vac output is required.

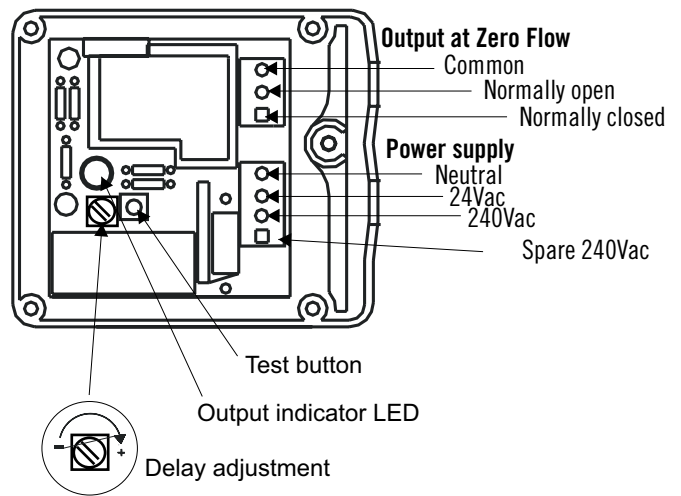
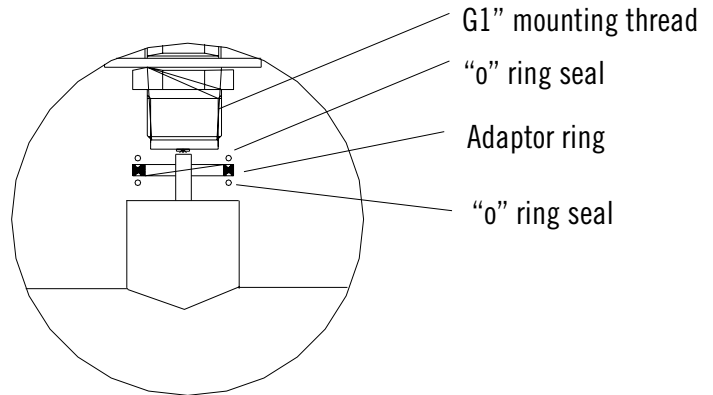
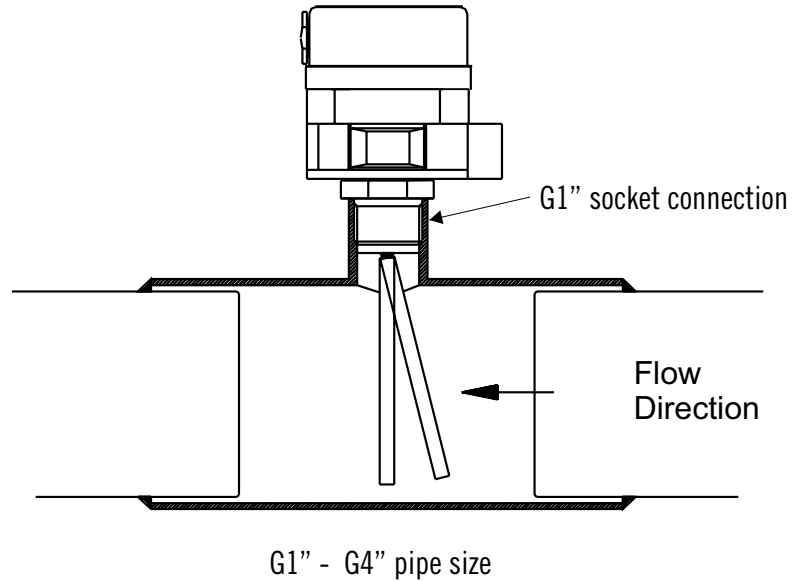

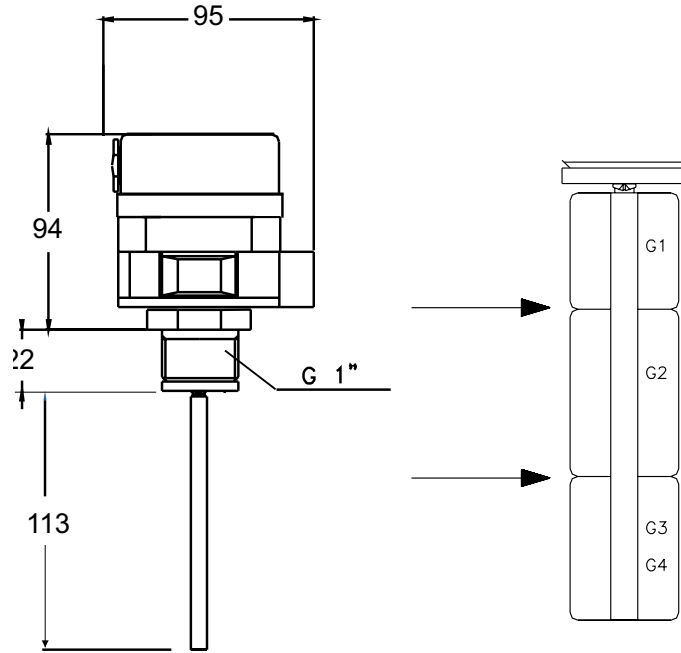

Datasheets provided by Sensata Technologies, Inc., its subsidiaries and/or affiliates ("Sensata") are solely intended to assist third parties ("Buyers") who are developing systems that incorporate Sensata products (also referred to herein as "components"). Buyer understands and agrees that Buyer remains responsible for using its independent analysis, valuation, and judgment in designing Buyer's systems and products. Sensata datasheets have been created using standard laboratory conditions and engineering practices. Sensata has not conducted any testing other than that specifically described in the published documentation for a particular datasheet. Sensata may make corrections, enhancements, improvements, and other changes to its datasheets or components without notice. Buyers are authorized to use Sensata datasheets with the Sensata component(s) identified in each particular datasheet. HOWEVER, NO OTHER LICENSE, EXPRESS OR IMPLIED, BY ESTOPPEL OR OTHERWISE TO ANY OTHER SENSATA INTELLECTUAL PROPERTY RIGHT, AND NO LICENSE TO ANY THIRD PARTY TECHNOLOGY OR INTELLECTUAL PROPERTY RIGHT, IS GRANTED HEREIN. SENSATA DATASHEETS ARE PROVIDED "AS IS". SENSATA MAKES NO WARRANTIES OR REPRESENTATIONS WITH REGARD TO THE DATASHEETS OR USE OF THE DATASHEETS, EXPRESS, IMPLIED, OR STATUTORY, INCLUDING ACCURACY OR COMPLETENESS. SENSATA DISCLAIMS ANY WARRANTY OF TITLE AND ANY IMPLIED WARRANTIES OF MERCHANTABILITY, FITNESS FOR A PARTICULAR PURPOSE, QUIET ENJOYMENT, QUIET POSSESSION, AND NON-INFRINGEMENT OF ANY THIRD PARTY INTELLECTUAL PROPERTY RIGHTS WITH REGARD TO SENSATA DATASHEETS OR USE THEREOF.

All products are sold subject to Sensata's terms and conditions of sale supplied at www.sensata.com. SENSATA ASSUMES NO LIABILITY FOR APPLICATIONS ASSISTANCE OR THE DESIGN OF BUYERS' PRODUCTS. BUYER ACKNOWLEDGES AND AGREES THAT IT IS SOLELY RESPONSIBLE FOR COMPLIANCE WITH ALL LEGAL, REGULATORY, AND SAFETY-RELATED REQUIREMENTS CONCERNING ITS PRODUCTS, AND ANY USE OF SENSATA COMPONENTS IN ITS APPLICATIONS, NOTWITHSTANDING ANY APPLICATIONS-RELATED INFORMATION OR SUPPORT THAT MAY BE PROVIDED BY SENSATA.

Mailing Address: Sensata Technologies, Inc., 529 Pleasant Street, Attleboro, MA 02703, USA

CONTACT US

Sensata Technologies
 Jan Tinbergenstraat 80
 7559 SP Hengelo
 The Netherlands
 1-508-236-3800
 +44 (0)1202 897969
cynergy3.enquiries@sensata.com