

FCHM SERIES

HYDROMATIC PUMP CONTROL MODULE



A compact unit, which combines all the functions of a complete pressurising system, ie. Pressure Switch, Dry Running cut-out, Control Panel, Pressure Reservoir and Non-return Valve. The system employs a hydraulic chamber, equipped with a damping system to protect against water hammer, and a patented electromechanical control board, to be connected to 240Vac power source, with an internal 24V secondary circuit.

Compared with conventional systems this is not only more compact, but easier and quicker to install, and makes for significant energy savings and reduced pump wear. It is also maintenance free, as the pressurisation unit does not require precharging with air.

This system combines the versatility and control of conventional pressure switches with the advantages of pressure/flow switches. Avoids the need for pressure reservoirs, along with their associated maintenance costs.

Features

- Start up pressure 1-3.5 bar, adjustable
- Dry running cut out and foot valve
- Visual Indication and manual reset for water circuit faults
- Pressure gauge for easy set up
- Auxiliary fuse to protect pump control circuit

SPECIFICATIONS

Supply voltage	240Vac 50-60Hz
Max operating power	2HP
IP Rating	65
Max pressure	10 bar
Max flow rate	100 l/min
Max fluid temperature	60°C
Max ambient temperature	60°C
Minimum start-up pressure adjustable	1 - 3.5 bar
Pump shutdown Flowrate	1.5L/min.
Minimum output pressure(Pump max pressure)	> = start-up pressure plus 1.0.bar

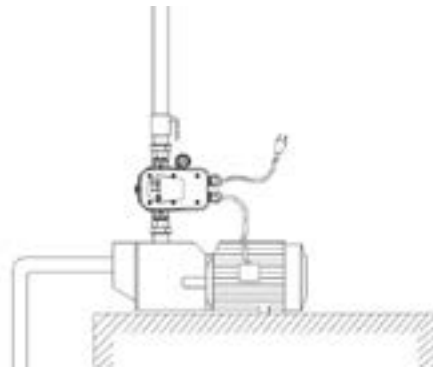
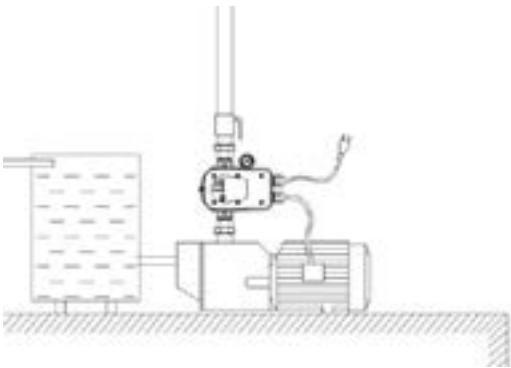
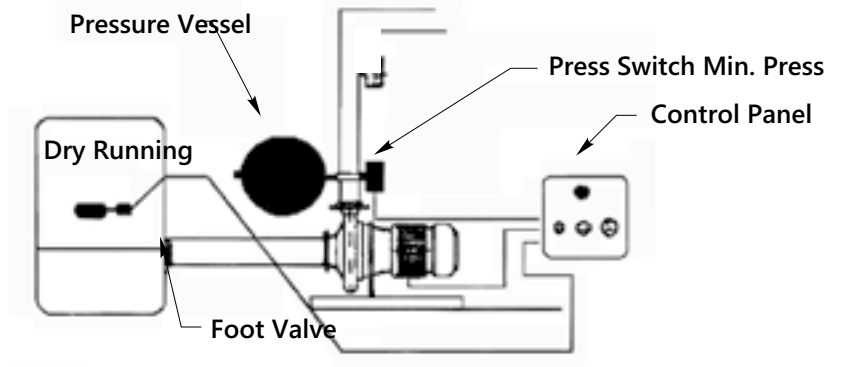
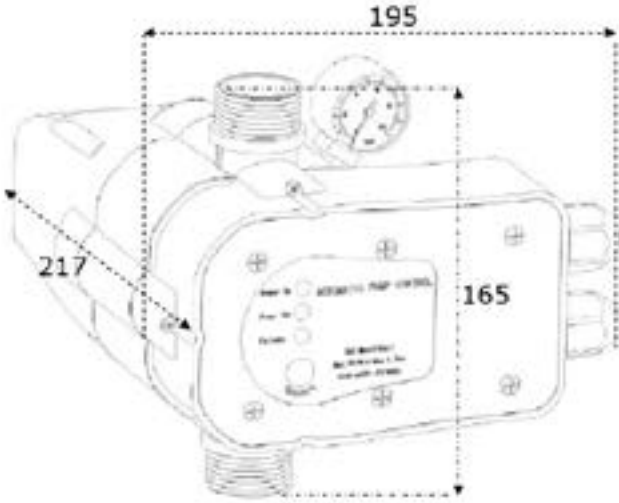

from
Submersible
pump

Always install a pump that develops a maximum output pressure that is at least 1 bar greater than the required minimum start up pressure.

If the head to be pumped is greater than 15m, it is necessary to increase the start up pressure setting e.g. 20m head requires at least 2.5 bar start up pressure, 25m head requires at least 3 bar start up pressure.

To increase the start up pressure setting:

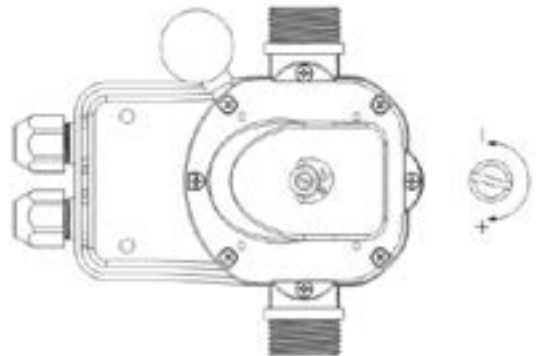

Wiring for 1phase pumps up to 2HP

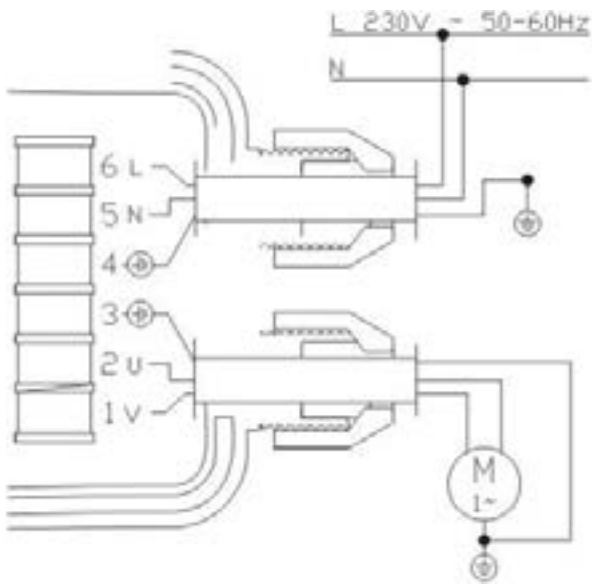

Wiring for 1phase pumps over 2HP

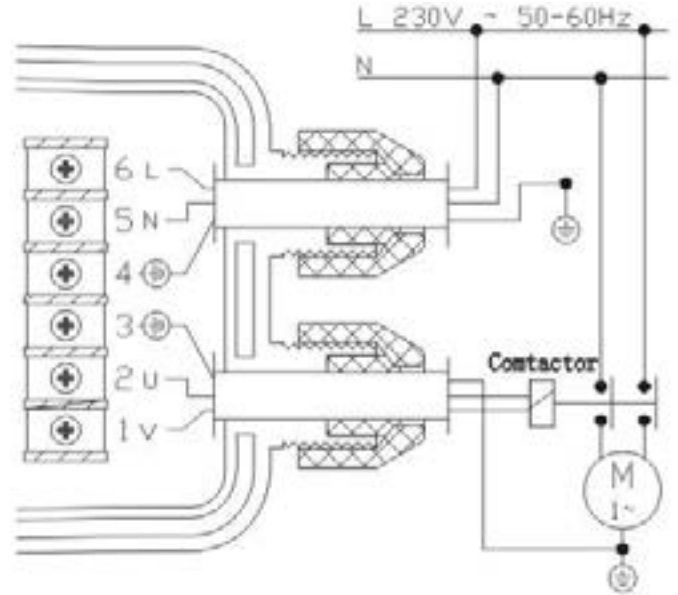

Wiring for 3phase pumps

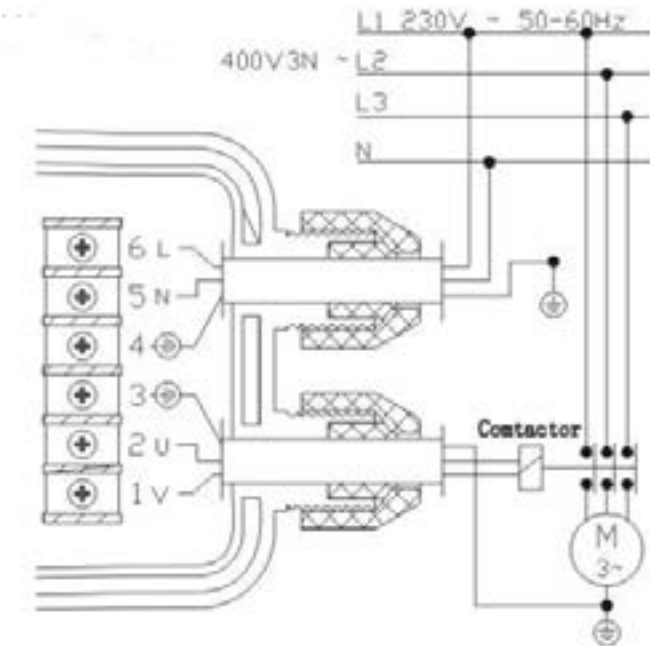

Datasheets provided by Sensata Technologies, Inc., its subsidiaries and/or affiliates ("Sensata") are solely intended to assist third parties ("Buyers") who are developing systems that incorporate Sensata products (also referred to herein as "components"). Buyer understands and agrees that Buyer remains responsible for using its independent analysis, valuation, and judgment in designing Buyer's systems and products. Sensata datasheets have been created using standard laboratory conditions and engineering practices. Sensata has not conducted any testing other than that specifically described in the published documentation for a particular datasheet. Sensata may make corrections, enhancements, improvements, and other changes to its datasheets or components without notice. Buyers are authorized to use Sensata datasheets with the Sensata component(s) identified in each particular datasheet. HOWEVER, NO OTHER LICENSE, EXPRESS OR IMPLIED, BY ESTOPPEL OR OTHERWISE TO ANY OTHER SENSATA INTELLECTUAL PROPERTY RIGHT, AND NO LICENSE TO ANY THIRD PARTY TECHNOLOGY OR INTELLECTUAL PROPERTY RIGHT, IS GRANTED HEREIN. SENSATA DATASHEETS ARE PROVIDED "AS IS". SENSATA MAKES NO WARRANTIES OR REPRESENTATIONS WITH REGARD TO THE DATASHEETS OR USE OF THE DATASHEETS, EXPRESS, IMPLIED, OR STATUTORY, INCLUDING ACCURACY OR COMPLETENESS. SENSATA DISCLAIMS ANY WARRANTY OF TITLE AND ANY IMPLIED WARRANTIES OF MERCHANTABILITY, FITNESS FOR A PARTICULAR PURPOSE, QUIET ENJOYMENT, QUIET POSSESSION, AND NON-INFRINGEMENT OF ANY THIRD PARTY INTELLECTUAL PROPERTY RIGHTS WITH REGARD TO SENSATA DATASHEETS OR USE THEREOF.

All products are sold subject to Sensata's terms and conditions of sale supplied at www.sensata.com. SENSATA ASSUMES NO LIABILITY FOR APPLICATIONS ASSISTANCE OR THE DESIGN OF BUYERS' PRODUCTS. BUYER ACKNOWLEDGES AND AGREES THAT IT IS SOLELY RESPONSIBLE FOR COMPLIANCE WITH ALL LEGAL, REGULATORY, AND SAFETY-RELATED REQUIREMENTS CONCERNING ITS PRODUCTS, AND ANY USE OF SENSATA COMPONENTS IN ITS APPLICATIONS, NOTWITHSTANDING ANY APPLICATIONS-RELATED INFORMATION OR SUPPORT THAT MAY BE PROVIDED BY SENSATA.

Mailing Address: Sensata Technologies, Inc., 529 Pleasant Street, Attleboro, MA 02703, USA

CONTACT US

Sensata Technologies
 Jan Tinbergenstraat 80
 7559 SP Hengelo
 The Netherlands
 1-508-236-3800
 +44 (0)1202 897969
cynergy3.enquiries@sensata.com