

# R&D Battery Safety CAN Sensor User Manual

Generation 1



## Revision History

Revision	Comment	Author	Date
0.1	Creation of document	Joe Holdsworth	20-Jul-21
1.0	First release	Joe Holdsworth	21-Jul-21
2.0	Corrections and fixing links	Joe Holdsworth	21-Aug-02
3.0	Added info to quick setup	Joe Holdsworth	21-Nov-15
4	Updated input voltage range	Claire Bishop	26/02/2024
5	Updated Metis Engineering logo	Claire Bishop	22/05/2024
6	Corrected Max update rate for each parameter in Table 1	Claire Bishop	20/06/2024

# Contents

System Overview .....	4
Units Specification.....	5
Sensor .....	5
Environmental.....	5
Electrical .....	6
Connection.....	6
Electrical.....	7
Mating Connector .....	7
Crimps .....	7
CAN Termination .....	7
Mounting.....	8
JWPF Dimensions .....	8
Pigtail Dimensions .....	9
Suggested Installation .....	10
CAN Interface.....	11
Quick Start Guide .....	11
Step 1: Power Up Unit .....	11
Step 2: Connect CAN Tool.....	11
Step 3: Enter Setup mode.....	13
Step 4: Save Setup .....	13
Step 5: Reset to Factory Defaults.....	13
Step 6: Calibrate the Sensors .....	13
CAN Message Format.....	14
CAN Message Summary.....	14
BS Config (0x30A[default]).....	15
Configuration CAN Message .....	15
Common CAN Message Types .....	16
Heartbeat (0x00_Heartbeat) .....	17
Enter Setup Command (0x01_Cmd_Enter_Setup) .....	17
Save Setup Command (0x02_Cmd_Save_Setup) .....	17
Cancel Setup Command (0x03_Cmd_Cancel_Setup) .....	18
Reset Unit To Factory Default Settings (0x04_Cmd_Rst_to_Factory_Defaults).....	18
Get CAN Bus Speed (0x05_Cmd_Get_CAN_Bus_Speed).....	18
Set CAN Bus Speed (0x06_Cmd_Set_CAN_Bus_Speed).....	18
Received CAN Bus Speed (0x07_Resp_CAN_Bus_Speed).....	19
Get CAN start address (0x08_Cmd_Get_CAN_Start_Address) .....	19
Set CAN start address (0x09_Cmd_Set_CAN_Start_Address) .....	20
Received CAN Start Address (0x0A_Resp_CAN_Start_Address).....	20

## R&D Battery Safety CAN Sensor User Manual

Reboot Device (0x0E_Cmd_Reboot_Device) .....	21
Get Software Version (0x0F_Cmd_Get_Software_Version) .....	21
Software Version Response (0x10_Resp_Software_Version) .....	21
BS Sensor Settings .....	22
Get Gas Update Rate (0x30_Cmd_Get_Gas_Update_ms) .....	22
Set Gas Update Rate (0x31_Cmd_Set_Gas_Update_ms) .....	22
Gas Update Response (0x32_Resp_Gas_Update_ms).....	22
Get Water and Temperature Update Rate (0x33_Cmd_Get_W_and_T_Update_ms).....	23
Set Water and Temperature Update Rate (0x34_Cmd_Set_W_and_T_Update_ms) .....	23
Water and Temperature Update Response (0x35_Resp_W_and_T_Update_ms).....	23
Get Pressure Update Rate (0x36_Cmd_Get_Pressure_Update_ms).....	24
Set Pressure Update Rate (0x37_Cmd_Set_Pressure_Update_ms) .....	24
Pressure Update Response (0x38_Resp_Pressure_Update_ms) .....	24
Get Gas CAN message output on or off (0x3C_Cmd_Get_Gas_Msg_On) .....	25
Set Gas CAN message output on or off (0x3D_Cmd_Set_Gas_Msg_On) .....	25
Gas CAN message output on or off Response (0x3E_Resp_Gas_Msg_On) .....	25
Get Water and Temperature CAN message output on or off (0x3F_Cmd_Get_W_and_T_Msg_On).....	26
Set Water and Temperature CAN message output on or off (0x40_Cmd_Set_W_and_T_Msg_On).....	26
Water and Temperature CAN message output on or off Response (0x41_Resp_W_and_T_Msg_On) .....	26
Get Pressure CAN message output on or off (0x42_Cmd_Get_Pressure_Msg_On) .....	27
Set Pressure CAN message output on or off (0x43_Cmd_Set_Pressure_Msg_On).....	27
Pressure CAN message output on or off Response (0x44_Resp_Pressure_Msg_On).....	27
Set Air Temperature Offset (0x55_Cmd_Set_AT_Offset) .....	28
Air Temperature Offset Response (0x56_Resp_AT_Offset) .....	28
Get Baseline Period (0x5D_Cmd_Get_Baseline_Period) .....	29
Set Baseline Period (0x5E_Cmd_Set_Baseline_Period) .....	29
Baseline Period Response (0x5F_Resp_Baseline_Period) .....	29
BS_Pressure (0x30B [default]).....	30
BS_Water_and_Temp (0x30C [default]).....	31
BS_Gas (0x30D [default]) .....	32
List of Tables .....	33
List of Figures.....	34

## R&D Battery Safety CAN Sensor User Manual

# System Overview

This CAN based Battery Safety (BS) Sensor measures:

- Absolute pressure from 200 to 5500 mbar (0.2 to 5.5 Bar)
- Air Temperature from -30 to 120 degrees C
- Volatile Organic Compounds (VOC) in ppb
- Equivalent CO2 (eCO2) in ppm **(HVAC Systems only!)**
- Hydrogen/H2 in ppm
- Absolute air water content in mg/m3
- Relative Humidity in %
- Dew point temperature in degrees C.

The unit features a replaceable air filter which helps to filter out particulates to increase the life of the sensor.

The configurable CAN bus speed and address along with the supplied DBC file allows easy integration into almost any vehicle with a CAN bus. This sensor can be used to analyse local air quality, for example it can be used in battery systems to detect early failures due to cell venting or vehicle HVAC systems.

The choice of 6 pin IP67 connector or 300mm pig tail, wide ranging input voltage and the small size and mass of the unit allows easy interface into most vehicles.

**If the unit is too close to a source of smoke or ignition it can permanently damage the units sensors.**

**The CO2 sensor is equivalent CO2 and can be up to 15% error on full scale, it should only be used as an indication of CO2 as it is derived from the readings from the H2 sensor. The unit comes factory calibrated and re-baselines itself every 10 minutes of power on time. The outputted value should be interpreted with care paying attention to the stated accuracy in the units specification section.**

## Units Specification

### Sensor

<b>Pressure Sensor</b>	Range	0.2 to 5.5	Bar
	Resolution	0.0001	Bar
	Accuracy (0.2 to 0.3 Bar)	+3	%FSS
	Accuracy (0.3 to 1.1 Bar)	0.0005	Bar
	Accuracy (1.1 to 5.5 Bar)	+3	%FSS
	Max Update Rate	100	Hz
<b>Air Temperature [1]</b>	Range	-30 to 123	°C
	Resolution	0.3	°C
	Accuracy	+1	°C
	Max Update Rate	10	Hz
<b>Volatile Organic Compounds (VOC's)</b>	Range	0 to 65534	ppb
	Resolution	2	ppb
	Accuracy (Worse Case)	15 [3]	%
	Max Update Rate	1	Hz
<b>Equivalent CO2 (eCO2)[2]</b>	Range	0 to 65534	ppm
	Resolution	2	ppm
	Accuracy (Worse Case)	15 [3]	%
	Max Update Rate	1	Hz
<b>H2</b>	Range	0 to 1000	ppm
	Resolution	0.02	ppm
	Accuracy (Worse Case)	10[3]	%
	Max Update Rate	1	Hz
<b>Absolute Humidity[4]</b>	Range	0 - 35000	mg/m <sup>3</sup>
	Resolution	70	mg/m <sup>3</sup>
	Accuracy (Worse Case)	3	%FSS
	Max Update Rate	10	Hz
<b>Dew Point</b>	Range	0-100	°C
	Resolution	0.5	°C
	Accuracy (Worse Case)	+2	°C
	Max Update Rate	10	Hz

TABLE 1 SENSOR PERFORMANCE

### Environmental

<b>Environment</b>	Operating temperature	-20 to +80	°C
	Dust and Water Ingress	IP65	
<b>Mechanical Shock (Max Values)</b>	Duration < 200µs	10000	g
	Duration < 1ms	2000	g
	Free Fall Distance	1.8	m
<b>Mass</b>		30	grams
<b>Dimensions</b>	Height x Width x Length	22x40x45	mm

TABLE 2 ENVIRONMENTAL PERFORMANCE INFORMATION

Electrical

<b>CAN [5]</b>	Baud Rates	1000, 500, 250	kbps
	Address Range[6]	1 (0x01) to 2042 (0x7FA). Default = 0x30A	decimal (Hex)
<b>Power</b>	Voltage Range	9-16	V
	Current (Sleep)	110 (10mA)	mA @ 12V
<b>Input Pins</b>	Voltage Range	2-28	V

TABLE 3 ELECTRICAL PERFORMANCE

Connection

<b>Cable Variant (standard is 300mm in length)</b>		
AWG	26	
Wire Spec	Raychem 55	
Cable Jacket	TE Flame Retardant -75 to +150 °C	
OD	3.1mm +-0.1mm	
<b>Connector Variant</b>		
On Unit	B06B-JWPF-SK-R	
Mating [7]	06R-JWPF-VSLE-D	
Crimp	SWPR-001T-P025	
<b>Pin Outs</b>		
<b>Wire Colour</b>	<b>Pin No.</b>	<b>Function</b>
Brown	1	Not Used
Red	2	Supply Voltage
Black	3	Ground
Green	4	CAN High
White	5	CAN Low
Yellow	6	Factory Reset [8]

TABLE 4 CONNECTION INFORMATION

[1] Air Temperature Accuracy is dependent on installation, heat from the sensor itself can affect this

[2] eCO2 values are derived from H2 and should only be used in HVAC applications

[3] % of meas. value, sensor drift is 1.3% of measured value per year of operation, 90% of the sensors will be within the typical accuracy tolerance

[4] Humidity only valid from 0 to 80 degC IC temperature

[5] The default settings are 1000kbps and start address 778 (0x30A), the unit has no CAN termination

[6] The unit uses 4 CAN address which are in consecutive order from address that the unit is set to

[7] This connector is not supplied with the unit

[8] To reset the unit to factory settings pull this from 2.5v to supply voltage on unit power up

Mating Connector

Part No.: 06R-JWPF-VSLE-D

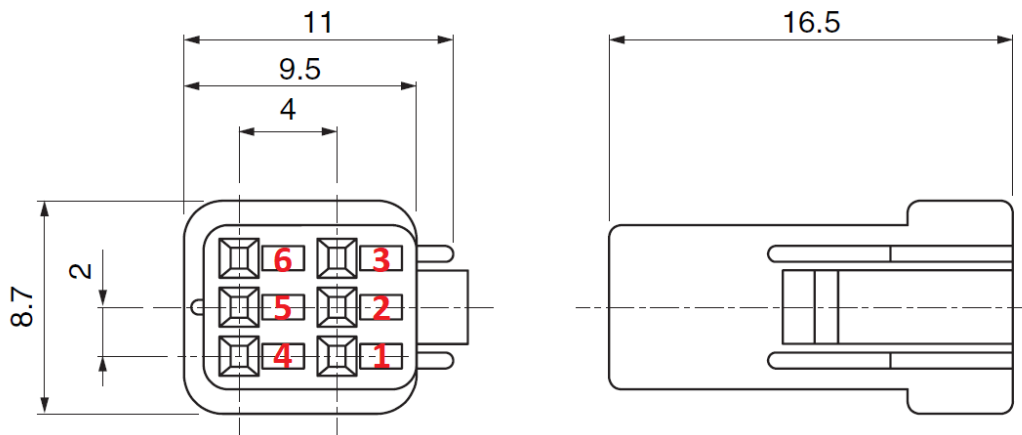

FIGURE 1 MATING CONNECTOR PIN NUMBERING (TOP DOWN VIEW)

Crimps

Crimp Part No.: SWPR-001T-P025

Crimp Tool Part No.: WC-JWPF

12" Pre-Crimped Cable Part No.: AJWPFJWPF22K305R

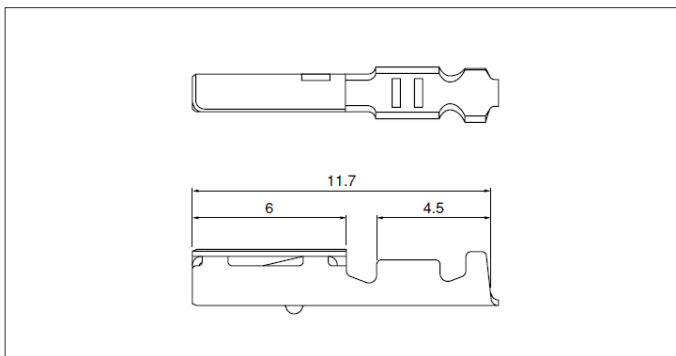

FIGURE 2 CONNECTOR CRIMP DETAILS

Model No.	Applicable wire		Insulation O.D (mm)	Q'ty / reel
	mm <sup>2</sup>	AWG#		
SWPR-001T-P025	0.13~0.33	26~22	1.4~1.7	8,200
Material and Finish				
Copper alloy, tin-plated (reflow treatment)				
RoHS compliance				
Contact	Crimping machine	Applicator		
		Crimp applicator	Dies	Crimp applicator with dies
SWPR-001T-P025	AP-K2N	MKS-L	MK/SWPR/T-001-025	APLMK SWPR/T001-025
		—	—	—

CAN Termination

The unit does not have a termination resistor.

Mounting

Mount using 4 x M2.5 bolts and washer to protect between the bolt and anodized aluminum base.

JWPF Dimensions

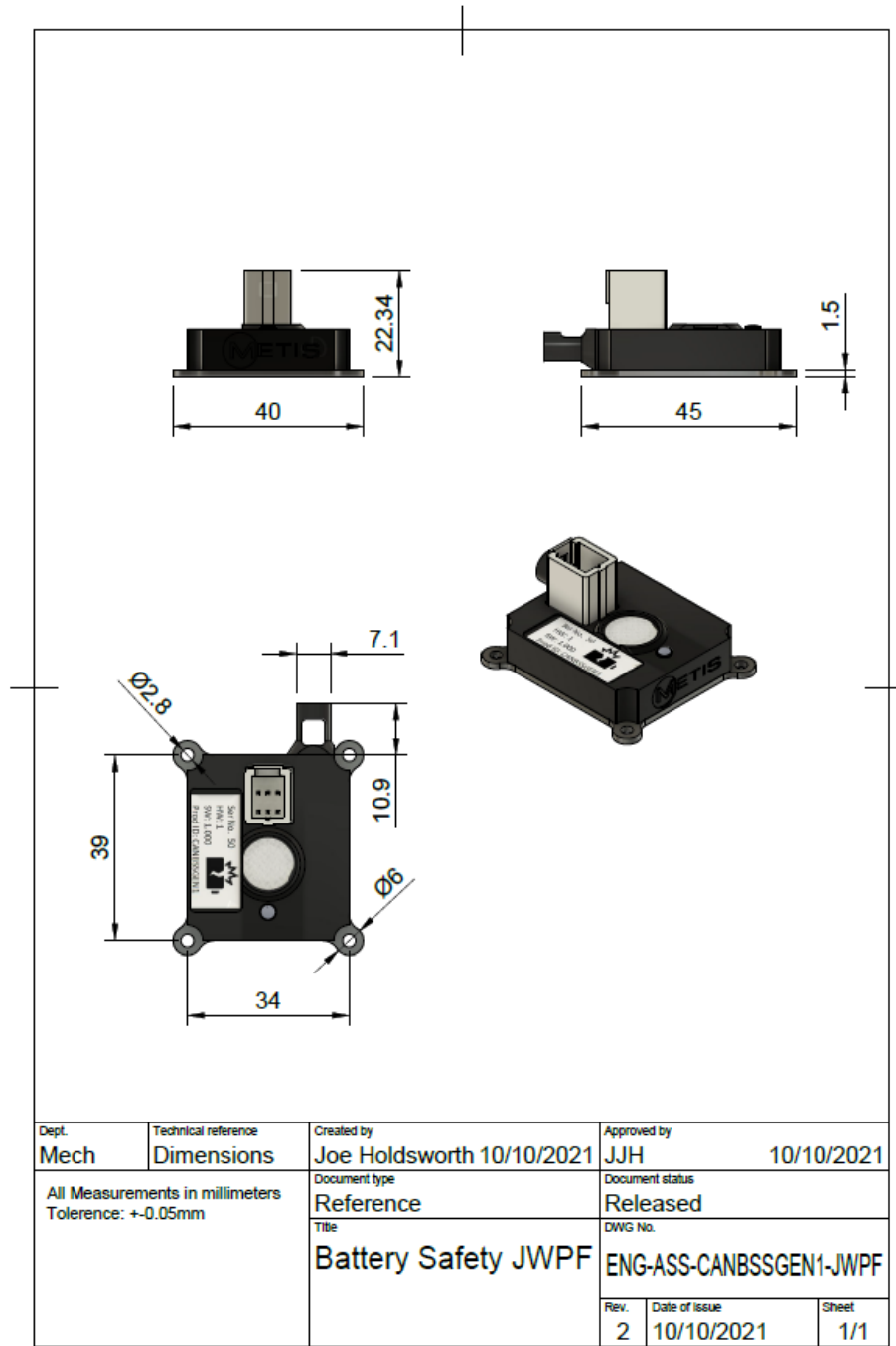

FIGURE 3 JWPF SENSOR DIMENSIONS

R&D Battery Safety CAN Sensor User Manual  
 Pigtail Dimensions

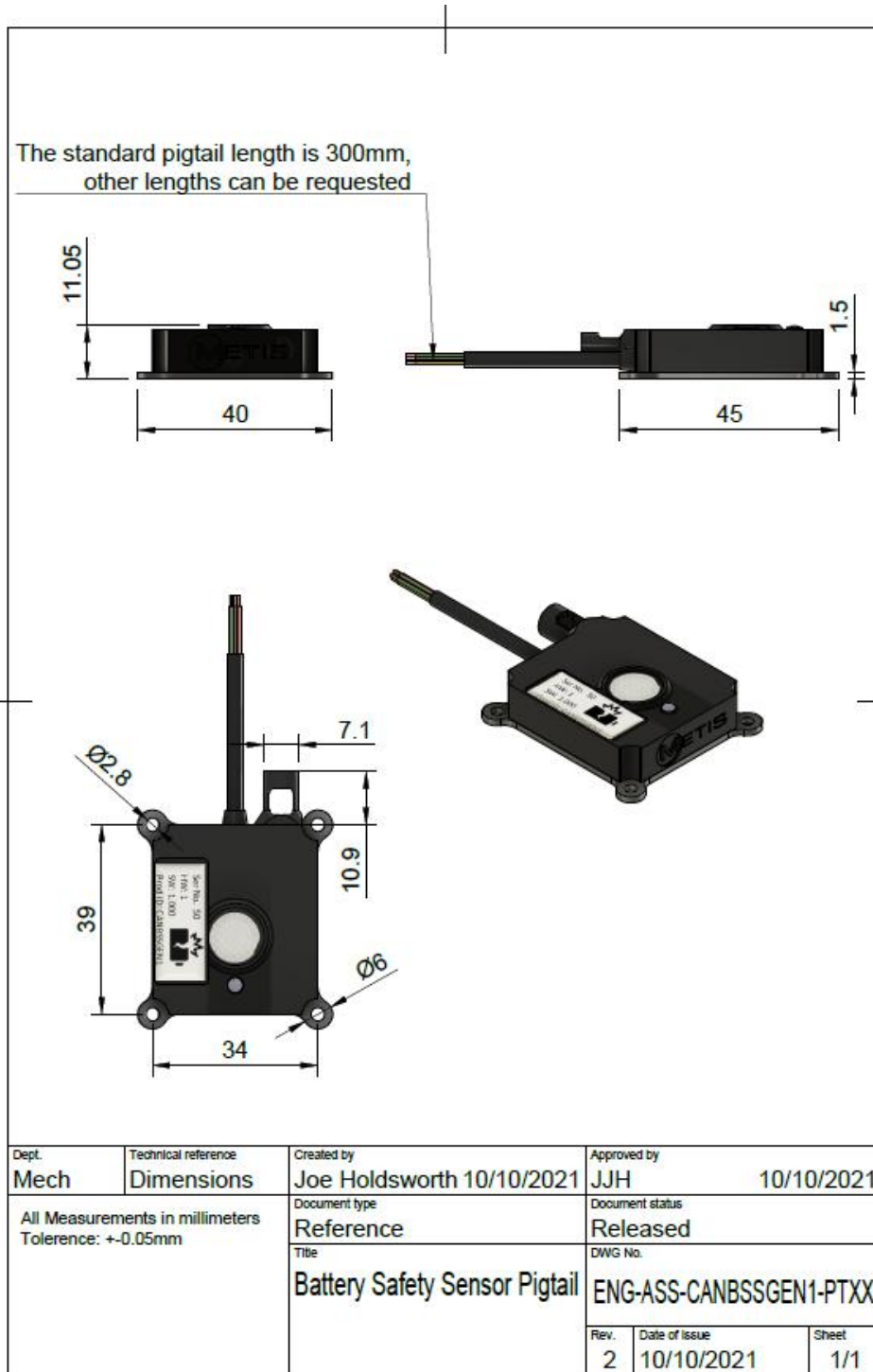
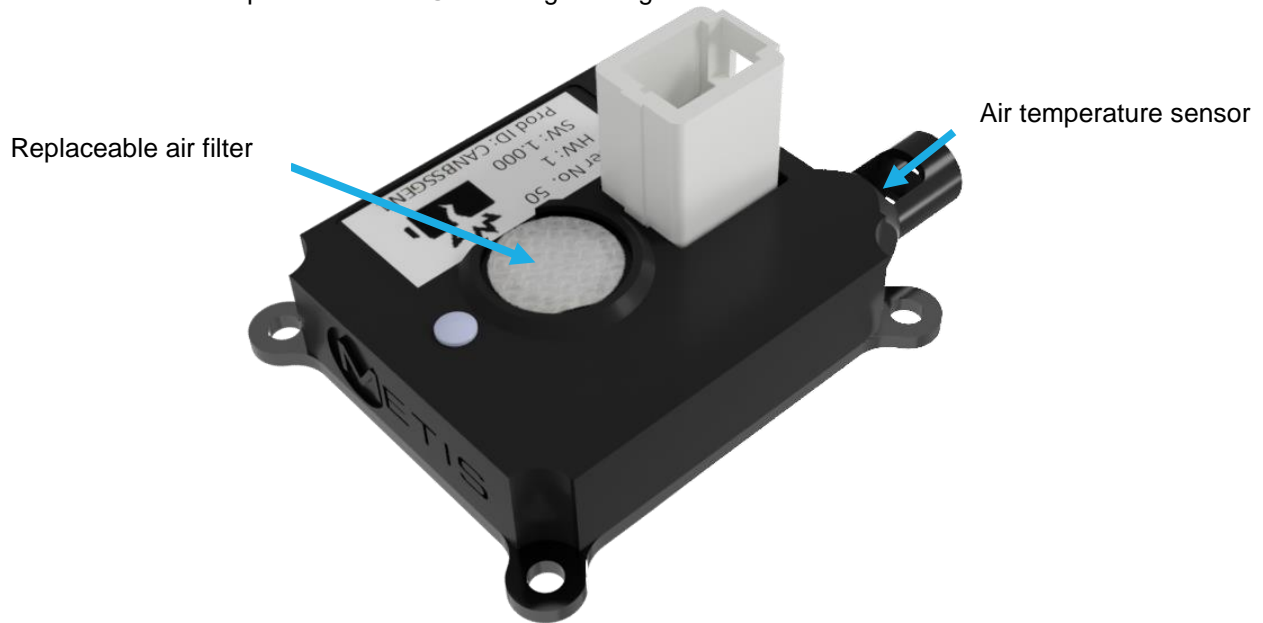

FIGURE 4 PIGTAIL SENSOR DIMENSIONS

## Suggested Installation

Install at least 1m away from source of flame and soot, otherwise the unit can be permanently damaged. Replace the filter if it becomes dirty, the circular air filter has an adhesive backing that allows it to be peeled off and replaced. Please request additional filters if required from [info@metisengineering.com](mailto:info@metisengineering.com).



**FIGURE 5 MECHANICAL INSTALLATION ORIENTATION**

The accuracy of the air temperature sensor is sensitive to how the unit is mounted, the unit produces a small amount of heat, convected heat from the sensor or if the heat is not conducted away from the sensor will lead to an offset in the air temperature vs real air temperature. The temperature sensor's value can be offset by configuring it via a CAN message.

To avoid convected heat the unit should be mounted flat, if the unit is mounted on its side the air temperature sensor should be mounted pointing down.

## CAN Interface

### Quick Start Guide

This section gives a quick overview of how to change settings on the device.

To see Default settings the unit ships with, please refer to the CAN Message Summary section.

#### Step 1: Power Up Unit

Make sure power and CAN is connected to the device using the pin outs previously described in the Figure 1 Mating Connector Pin Numbering (Top Down View) section.

If the CAN bus is unterminated or the unit is the only node on the CAN bus, please place a 120Ohm resistor between CAN high and CAN low lines.

Apply 9-14VDC to the unit at  $\geq 120\text{mA}$ .

#### Step 2: Connect CAN Tool

Ideally use a CAN tool such as PCAN or CANalyser.

Make sure the CAN bus connection settings in the tool match the settings specified in the unit's default settings section, i.e. 11bit address and 1MBit CAN bus speed.

Import the unit's DBC or symbols file received into the CAN tool.

Start the CAN interface on the Computer.

The CAN Heartbeat message will appear from the unit and other CAN Devices that may be on the bus. If not, then check the following;

1. The unit has power
2. The settings are correct
3. The CAN bus is terminated correctly
4. CAN high and low lines are the correct way round

Figure 5 shows the default message output from the unit. Please take note of the Unique ID value and the Key value. These will be required when entering Setup mode or saving any changes to the setup. Please be aware that the Key value changes each time a valid enter setup command has been received.

# R&D Battery Safety CAN Sensor User Manual

The screenshot displays the AQ-PCAN-Explorer software interface. The main window shows a table of CAN messages, categorized into 'Receive' and 'Transmit' sections. The 'Receive' section lists messages such as AQ\_Pressure, AQ\_Particle\_Sensor, AQ\_Water\_and\_Temp, AQ\_Gas, and AQ\_Config.0x00\_Heartbeat. The 'Transmit' section lists configuration-related messages like AQ\_Config.0x01\_Cmd\_Enter\_Setup, AQ\_Config.0x02\_Cmd\_Save\_Setup, and AQ\_Config.0x04\_Cmd\_Rst\_to\_Factory\_Defaults. A 'Properties' window is open on the right, showing details for a CAN message with CAN-ID 30A, Data Length 6, and DLC 6. The 'Connections' panel at the bottom shows a connection to 'Environment' on bus 1.

Bus	CAN-ID (...)	Type	Length	Symbol	Data	Timing ...	Cycle Ti...	Count
1	30B		4	AQ_Pressure	AbsolutePressure = 1020.16 mBar		10.1	16219
1	30D		6	AQ_Particle_Sensor	GreenLight = 227 ADC Count RedLight = 352 ADC Count IRLight = 851 ADC Count		50.0	3244
1	30C		8	AQ_Water_and_Temp	AirTemperature = 25.0 Deg C AbsoluteHumidity = 9884 mg/m^3 DewPointTemperature = 12.0 Deg C RelativeHumidity = 44.5 %		100.0	1622
1	30E		8	AQ_Gas	EquivalentCO2 = 438 ppm TotalVOC = 13 ppb Ethanol = 17695 ppm H2 = 12684 ppm		999.9	162
1	30A		8	AQ_Config.0x00_Heartbeat	UniquelD = 6925321 Status = Run Key = 2020 UnitType = Air Quality Gen 1		999.8	162

Bus	CAN-ID ...	Ty...	Le...	Symbol	Data	Cycle ...	Count	Tr...	Cre...
1	30A		6	AQ_Config.0x01_Cmd_Enter_Setup	UniquelD = 12075247 Key = 5502	Wait	0		User
1	30A		6	AQ_Config.0x02_Cmd_Save_Setup		Wait	0		User
1	30A		6	AQ_Config.0x04_Cmd_Rst_to_Factory_Defaults	UniquelD = 6925321 Key = 3190	Wait	0		User
1	30A		4	AQ_Config.0x39_Cmd_Get_AT_Offset	UniquelD = 6925321	Wait	0		User
1	30A		8	AQ_Config.0x3A_Cmd_Set_AT_Offset		Wait	0		User
1	30A		4	AQ_Config.0x3C_Cmd_Get_Baseline_Period	UniquelD = 6925321	Wait	0		User
1	30A		6	AQ_Config.0x3D_Cmd_Set_Baseline_Period		Wait	0		User

Bus	Name	Net Connection	Bit Rate	Status	Overruns	QXmtFulls	Options	Bus Load
1	Environment	AHRS@pcan_usb	1 Mbit/s	OK	0	0		

FIGURE 6 DEFAULT CAN MESSAGE OUTPUT

To change any settings move to step 3. If not required move to step 6 and calibrate the device (calibration is not required for every sensor).

## R&D Battery Safety CAN Sensor User Manual

### Step 3: Enter Setup mode

The Heartbeat message should give:

1. A Unique ID value.
2. A Key value.
3. The unit type sending the heartbeat message.
4. The run mode - this should be 'Run' if the unit has just powered up.

Take note of both the Unique ID value and the Key value.

Create an Enter Setup Mode message and populate the Unique ID field and Key field with the values noted from the heartbeat message.

Send the 'Enter Setup Mode' Command to the unit -this should only be sent once.

The next Heartbeat message received from the unit should have the run mode changed to 'Unit in Setup mode'. If this is not the case check your unique ID and Key value match those in the heartbeat message.

Once in setup mode the unit can be configured using other the other config messages.

Any changes that have been made will not be applied until a 'Save Setup' command has been sent.

To cancel any changes prior to the 'Save Setup' command, send the 'Cancel Setup' command or power cycle the device.

### Step 4: Save Setup

To apply any configuration changes, send the 'Save Setup' command with the Unique ID and Key value field populated with the current value in the heartbeat message.

Note: The Key value changes each time a successful message has been received.

Any changes to the unit will not be applied until a 'Save Setup' command has been sent.

### Step 5: Reset to Factory Defaults

To restore factory settings connect the factory reset pin to the power supply voltage and then power cycle the device.

If CAN communication is present a factory reset command can be sent to the unit.

### Step 6: Calibrate the Sensors

The unit comes factory calibrated. The only parameter that may need re calibrating is the measured air temperature. This can be done through the CAN interface and is described Battery Safety Sensor Settings section.

## CAN Message Format

Can Messages Identifier: 11bit

Data Format (all messages): Intel.

Termination: Unterminated (no 120 Ohm termination resistor)

Default CAN Bus Speed: 1MBps

Default CAN Start Address (decimal): 0x30A (778)

## CAN Message Summary

The unit uses up to 4 CAN message ID's.

Default CAN Address Hex (Decimal)	Message Name	Description	Frequency Sent from Unit	Frequency To Unit
0x30A (778)	BS_Config	Used to send and receive configuration settings and values from the unit. This address is also used by the unit to send its heart beat message. Functionality is selected by changing the multiplexor value field in this message	1000ms (Heartbeat)	User dependant
0x30B (779) [1 + Config Address]	BS_Pressure	Absolute pressure output wide and narrow and	10ms	NOT APPLICABLE
0x30C (780) [2 + Config Address]	BS_Water_and_Temp	Absolute humidity, dew point, relative humidity output, air temp	100ms	NOT APPLICABLE
0x30D (771) [3 + Config Address]	BS_Gas	H2, Ethanol, VOC, eCO2	50ms	NOT APPLICABLE

TABLE 5 CAN MESSAGE OUTPUT SUMMARY

## BS Config (0x30A[default])

### Configuration CAN Message

CAN ID: Please see unit's default CAN start address details in the unit specific CAN message section.

Overview: This CAN message is used to send configuration commands to the unit and is also used to receive configuration data from the unit. To put the unit into Setup mode and any other commands CAN messages must be sent to this CAN address. The different commands sent to this address are selected by changing the Message Type Field.

Layout:

Byte(s)	Data Type	Name	Description
0 – 2	Unsigned 24 bit integer	Unique ID	The unit's unique identifier, enabling the user to distinguish between multiple unit's on the same CAN bus.
3	Unsigned 8 bit integer	Message Type	This field is a multiplexor used to identify the message type.  Mux values 0x00(0) to 0x29(41) are common across all units. Please refer to the common CAN message section.  Mux values 0x30(42) to 0xFF(255) change depending on what particular type the unit is being used. Please refer to the unit specific CAN message section.
4-7 (length can vary depending on message type)	Variable	Variable	The remaining 4 bytes are used depending on the command or data being sent back from the unit, not all 8 bytes are populated in every message.

TABLE 6 CAN CONFIGURATION MESSAGE

## R&D Battery Safety CAN Sensor User Manual

### Common CAN Message Types

Overview: These are the multiplexor message ID's that populate byte 3 of the configuration CAN message. The multiplexor messages highlighted in grey cells only work if the unit is in Setup mode.

Hex (Decimal) Value	Purpose	CAN DBC Name	Description
0x00 (0)	Heartbeat	0x00_Heartbeat	Message that gets sent out to indicate the unit is alive on the CAN bus, its status and what the unit type is.
0x01 (1)	Enter Setup	0x01_Cmd_Enter_Setup	Command sent to unit to put it into setup mode, <b>the unit needs to be in setup mode to make any configuration changes to the unit.</b>
0x02 (2)	Save Setup	0x02_Cmd_Save_Setup	Command to save any configuration changes that have been made whilst the unit was in Setup mode. <b>In order to apply any configuration changes this needs to be sent.</b> The unit reboots after this message is sent.
0x03 (3)	Cancel Setup	0x03_Cmd_Cancel_Setup	Command to cancel any changes that have been made in the current Setup mode.
0x04 (4)	Reset Unit to Factory Defaults	0x04_Cmd_Rst_to_Factory_Defaults	Resets the unit to factory defaults.
0x05 (5)	Get the CAN bus speed	0x05_Cmd_Get_CAN_Bus_Speed	Request the unit to send the current CAN bus speed. [1]
0x06 (6)	Set the CAN bus speed	0x06_Cmd_Set_CAN_Bus_Speed	Set the unit's CAN bus speed.
0x07 (7)	CAN bus speed response	0x07_Resp_CAN_Bus_Speed	The unit's response message indicating the current CAN bus speed.[1]
0x08 (8)	Get the CAN start address	0x08_Cmd_Get_CAN_Start_Address	Request the unit to send the current CAN start address. [1]
0x09 (9)	Set the CAN start address	0x09_Cmd_Set_CAN_Start_Address	Set the unit's CAN bus start address.
0x0A (10)	CAN bus start address response	0x0A_Resp_CAN_Start_Address	The unit's response message indicating the current CAN bus start address for the unit.[1]
0x0E (14)	Reboot the unit	0x0E_Cmd_Reboot_Device	Reboot the unit
0x0F (15)	Get the unit software version	0x0F_Cmd_Get_Software_Version	Get the software version on the unit
0x10 (16)	Software version response	0x10_Resp_Software_Version	The unit's response message to the software version on the device.

TABLE 7 CONFIGURATION MESSAGE TYPES

[1] If the value has been reconfigured but not saved the unit will send the reconfigured value.

## R&D Battery Safety CAN Sensor User Manual

### Heartbeat (0x00\_Heartbeat)

Mux Value Hex (Decimal): 0x00 (0)

Type: Transmitted from unit

Frequency: 2000ms

Layout:

Byte(s)	Data Type	Name	Description
0 – 2	Unsigned 24 bit integer	Unique ID	Unique ID
3	Unsigned 8 bit integer	Message Type	<b>0x00</b> – Heartbeat
4-5	Unsigned 16 bit integer	Key	This value is used to enter Setup mode, save setup or restore the unit back to factory defaults.  Values Range from 1 to 10000.
6	Unsigned 8 bit integer	Status	The status of the unit: <ol style="list-style-type: none"><li>1. Run – normal operation, no configuration changes can be made.</li><li>2. Unit in Setup mode – configuration can be changed.</li></ol>
7	Unsigned 8 bit integer	Unit Type	The type of unit attached to the bus e.g. a value of 0x00 is a standard CAN AHRS unit. Please see CAN unit types section for a complete list.

### Enter Setup Command (0x01\_Cmd\_Enter\_Setup)

Mux Value Hex (Decimal): 0x01 (1)

Type: Sent to unit

Frequency: NOT APPLICABLE

Description: Sending this command with the correct Key value puts the unit into Setup mode. Until the unit is in Setup mode no configuration options can be changed.

Layout:

Byte(s)	Data Type	Name	Description
0 – 2	Unsigned 24 bit integer	Unique ID	Unique ID
3	Unsigned 8 bit integer	Message Type	<b>0x01</b> – Enter setup command
4-5	Unsigned 16 bit integer	Key	This value in this field <b>must</b> be the same as the Key value in the heartbeat message for the command to be accepted. The key value will change each time a correct one has been received.

### Save Setup Command (0x02\_Cmd\_Save\_Setup)

Mux Value Hex (Decimal): 0x02 (2)

Type: Sent to unit

Frequency: NOT APPLICABLE

Description: Sending this message with the correct key value in the key field will save any configuration changes that have been made during Setup mode.

Layout:

Byte(s)	Data Type	Name	Description
0 – 2	Unsigned 24 bit integer	Unique ID	Unique ID
3	Unsigned 8 bit integer	Message Type	<b>0x02</b> – Save setup command

## R&D Battery Safety CAN Sensor User Manual

4-5	Unsigned 16 bit integer	Key	This value in this field <b>must</b> be the same as the Key value in the heartbeat message for the command to be accepted. The key value will change each time a correct one has been received.
-----	-------------------------	-----	---

### Cancel Setup Command (0x03\_Cmd\_Cancel\_Setup)

Mux Value Hex (Decimal): 0x03 (3)

Type: Sent to unit

Frequency: NOT APPLICABLE

Description: Sending this message will exit any current Setup mode and **not** save any changes.

Layout:

Byte(s)	Data Type	Name	Description
0 – 2	Unsigned 24 bit integer	Unique ID	Unique ID
3	Unsigned 8 bit integer	Message Type	<b>0x03</b> – Cancel setup command

### Reset Unit To Factory Default Settings (0x04\_Cmd\_Rst\_to\_Factory\_Defaults)

Mux Value Hex (Decimal): 0x04 (4)

Type: Sent to unit

Frequency: NOT APPLICABLE

Description: Sending this message and a valid Key will reset the unit to factory default settings.

Layout:

Byte(s)	Data Type	Name	Description
0 – 2	Unsigned 24 bit integer	Unique ID	Unique ID
3	Unsigned 8 bit integer	Message Type	<b>0x04</b> – Restore to Factory Defaults command
4-5	Unsigned 16 bit integer	Key	This value in this field must be the same as the Key value in the heartbeat message for the command to be accepted. The key value will change each time a correct one has been received.

### Get CAN Bus Speed (0x05\_Cmd\_Get\_CAN\_Bus\_Speed)

Mux Value Hex (Decimal): 0x05 (5)

Type: Sent to unit

Frequency: NOT APPLICABLE

Description: This message only works if the unit is in Setup mode. If this CAN message is sent the unit will respond with the configured CAN bus speed.

Layout:

Byte(s)	Data Type	Name	Description
0 – 2	Unsigned 24 bit integer	Unique ID	Unique ID
3	Unsigned 8 bit integer	Message Type	<b>0x05</b> – Get CAN bus speed command

### Set CAN Bus Speed (0x06\_Cmd\_Set\_CAN\_Bus\_Speed)

Mux Value Hex (Decimal): 0x06 (6)

Type: Sent to unit

Frequency: NOT APPLICABLE

## R&D Battery Safety CAN Sensor User Manual

Description: This message only works if the unit is in Setup mode. This will set the CAN bus speed.

Layout:

Byte(s)	Data Type	Name	Description
0 – 2	Unsigned 24 bit integer	Unique ID	Unique ID
3	Unsigned 8 bit integer	Message Type	<b>0x06</b> – Set CAN bus speed command
4	Unsigned 8 bit integer	CAN bus speed	The below values in this field correspond to the following CAN speeds:  0 = 1000kbps (default) 1 = 800kbps 2 = 500kbps 3 = 250kbps 4 = 125kbps

## Received CAN Bus Speed (0x07\_Resp\_CAN\_Bus\_Speed)

Mux Value Hex (Decimal): 0x07 (7)

Type: Transmitted from unit

Frequency: NOT APPLICABLE

Description: This message only works if the unit is in Setup mode. This is a unit responds to a set or get CAN Bus Speed message.

Layout:

Byte(s)	Data Type	Name	Description
0 – 2	Unsigned 24 bit integer	Unique ID	Unique ID
3	Unsigned 8 bit integer	Message Type	<b>0x07</b> – CAN bus speed
4	Unsigned 8 bit integer	CAN bus speed	The below values in this field correspond to the following CAN speeds:  0 = 1000kbps (default) 1 = 800kbps 2 = 500kbps 3 = 250kbps 4 = 125kbps

## Get CAN start address (0x08\_Cmd\_Get\_CAN\_Start\_Address)

Mux Value Hex (Decimal): 0x08 (8)

Type: Sent to unit

Frequency: NOT APPLICABLE

Description: This message only works if the unit is in Setup mode. If this CAN message is sent the unit will respond with the configured CAN start address, the start address is the Configuration CAN address, any CAN messages specific to the unit's functions will be sent consecutively after this address.

Layout:

Byte(s)	Data Type	Name	Description
0 – 2	Unsigned 24 bit integer	Unique ID	Unique ID
3	Unsigned 8 bit integer	Message Type	<b>0x08</b> – get CAN start address

## R&D Battery Safety CAN Sensor User Manual

### Set CAN start address (0x09\_Cmd\_Set\_CAN\_Start\_Address)

Mux Value Hex (Decimal): 0x09 (9)

Type: Sent to unit

Frequency: NOT APPLICABLE

Description: This message only works if the unit is in Setup mode. If this CAN message is sent the unit it will set the new CAN start address and respond with the configured CAN start address. The start address is the Configuration CAN address, any CAN messages specific to the unit's functions will be sent consecutively after this address.

Layout:

Byte(s)	Data Type	Name	Description
0 – 2	Unsigned 24 bit integer	Unique ID	Unique ID
3	Unsigned 8 bit integer	Message Type	<b>0x09</b> – set CAN start address
4 - 5	Unsigned 11 bit integer	CAN address	A value between 0x000 (0) to 0x7FF (2047), this is the theoretical maxAHRSm start address, but this will actually be determined by the number of CAN addresses used up by the unit. MaxAHRSm start address = 2047 – number of CAN addresses used.

### Received CAN Start Address (0x0A\_Resp\_CAN\_Start\_Address)

Mux Value Hex (Decimal): 0x0A (10)

Type: Transmitted from unit

Frequency: NOT APPLICABLE

Description: This is the unit's response to a set or get CAN Bus start address message

Layout:

Byte(s)	Data Type	Name	Description
0 – 2	Unsigned 24 bit integer	Unique ID	Unique ID
3	Unsigned 8 bit integer	Message Type	<b>0x0A</b> – CAN start address
4 – 5	Unsigned 11 bit integer	CAN address	A value between 0x000 (0) to 0x7FF (2047), this is the theoretical maxAHRSm start address, but this will actually be determined by the number of CAN addresses used up by the unit. MaxAHRSm start address = 2047 – number of CAN addresses used.

## R&D Battery Safety CAN Sensor User Manual

### Reboot Device (0x0E\_Cmd\_Reboot\_Device)

Mux Value Hex (Decimal): 0x0E (14)

Type: Sent to unit

Frequency: NOT APPLICABLE

Description: Sending this message and a valid Key value will reboot the device.

Layout:

Byte(s)	Data Type	Name	Description
0 – 2	Unsigned 24 bit integer	Unique ID	Unique ID
3	Unsigned 8 bit integer	Message Type	<b>0x0E</b> – Reboot device command
4-5	Unsigned 16 bit integer	Key	This value in this field must be the same as the Key value in the heartbeat message for the command to be accepted. The key value will change each time a correct one has been received.

### Get Software Version (0x0F\_Cmd\_Get\_Software\_Version)

Mux Value Hex (Decimal): 0x0F (15)

Type: Sent to unit

Frequency: NOT APPLICABLE

Description: This message only works if the unit is in Setup mode. If this CAN message is sent the unit will respond with the configured sleep mode.

Layout:

Byte(s)	Data Type	Name	Description
0 – 2	Unsigned 24 bit integer	Unique ID	Unique ID
3	Unsigned 8 bit integer	Message Type	<b>0x0F</b> – Get unit's software version

### Software Version Response (0x10\_Resp\_Software\_Version)

Mux Value Hex (Decimal): 0x10 (16)

Type: Transmitted from unit

Frequency: NOT APPLICABLE

Description: This is a unit's response to a get software version message

Layout:

Byte(s)	Data Type	Name	Description
0 – 2	Unsigned 24 bit integer	Unique ID	Unique ID
3	Unsigned 8 bit integer	Message Type	<b>0x10</b> – Software version response
4 - 7	Float 32bit	Software Version	The unit reported software version.

## BS Sensor Settings

This section documents CAN messages used to configure settings for the Battery Safety (BS) Sensor. To change any settings the unit needs to be in Setup mode.

### Get Gas Update Rate (0x30\_Cmd\_Get\_Gas\_Update\_ms)

Mux Value Hex (Decimal): 0x30 (48)

Type: Sent to unit

Frequency: NOT APPLICABLE

Description: If this CAN message is sent the unit will respond with the configured CAN message update rate in milliseconds for the gas message.

Layout:

Byte(s)	Data Type	Name	Description
0 – 2	Unsigned 24 bit integer	Unique ID	Unique ID
3	Unsigned 8 bit integer	Message Type	<b>0x30</b> – Get unit's gas update rate

### Set Gas Update Rate (0x31\_Cmd\_Set\_Gas\_Update\_ms)

Mux Value Hex (Decimal): 0x31 (49)

Type: Sent to unit

Frequency: NOT APPLICABLE

Description: This message configures the unit's CAN message update rate in milliseconds of Gas values.

Layout:

Byte(s)	Data Type	Name	Description
0 – 2	Unsigned 24 bit integer	Unique ID	Unique ID
3	Unsigned 8 bit integer	Message Type	<b>0x31</b> – Set unit's gas update rate
4 - 5	Unsigned 16 bit integer	Update Rate	1000ms to 10000ms (1000ms is default)

### Gas Update Response (0x32\_Resp\_Gas\_Update\_ms)

Mux Value Hex (Decimal): 0x32 (50)

Type: Transmitted from unit

Frequency: NOT APPLICABLE

Description: This is the unit's response to a set or get gas update rate.

Layout:

Byte(s)	Data Type	Name	Description
0 – 2	Unsigned 24 bit integer	Unique ID	Unique ID
3	Unsigned 8 bit integer	Message Type	<b>0x32</b> – gas update response message
4 - 5	Unsigned 16 bit integer	Update Rate	1000ms to 10000ms (1000ms is default)

## R&D Battery Safety CAN Sensor User Manual

### Get Water and Temperature Update Rate (0x33\_Cmd\_Get\_W\_and\_T\_Update\_ms)

Mux Value Hex (Decimal): 0x33 (51)

Type: Sent to unit

Frequency: NOT APPLICABLE

Description: If this CAN message is sent the unit will respond with the configured CAN message update rate in milliseconds of the water and temperature values.

Layout:

Byte(s)	Data Type	Name	Description
0 – 2	Unsigned 24 bit integer	Unique ID	Unique ID
3	Unsigned 8 bit integer	Message Type	<b>0x33</b> – Get unit's water and temperature update rate

### Set Water and Temperature Update Rate (0x34\_Cmd\_Set\_W\_and\_T\_Update\_ms)

Mux Value Hex (Decimal): 0x34 (52)

Type: Sent to unit

Frequency: NOT APPLICABLE

Description: This message configures the unit's CAN message update rate in milliseconds of water and temperature values.

Layout:

Byte(s)	Data Type	Name	Description
0 – 2	Unsigned 24 bit integer	Unique ID	Unique ID
3	Unsigned 8 bit integer	Message Type	<b>0x34</b> – Set unit's water and temperature update rate
4 - 5	Unsigned 16 bit integer	Update Rate	100ms to 1000ms (100ms is default)

### Water and Temperature Update Response (0x35\_Resp\_W\_and\_T\_Update\_ms)

Mux Value Hex (Decimal): 0x35 (53)

Type: Transmitted from unit

Frequency: NOT APPLICABLE

Description: This is the unit's response to a set or get water and temperature update rate.

Layout:

Byte(s)	Data Type	Name	Description
0 – 2	Unsigned 24 bit integer	Unique ID	Unique ID
3	Unsigned 8 bit integer	Message Type	<b>0x35</b> – water and temperature update rate response message
4 - 5	Unsigned 16 bit integer	Update Rate	100ms to 1000ms (100ms is default)

## R&D Battery Safety CAN Sensor User Manual

### Get Pressure Update Rate (0x36\_Cmd\_Get\_Pressure\_Update\_ms)

Mux Value Hex (Decimal): 0x36 (54)

Type: Sent to unit

Frequency: NOT APPLICABLE

Description: If this CAN message is sent the unit will respond with the configured CAN message update rate in milliseconds of the pressure value.

Layout:

Byte(s)	Data Type	Name	Description
0 – 2	Unsigned 24 bit integer	Unique ID	Unique ID
3	Unsigned 8 bit integer	Message Type	<b>0x36</b> – Get unit's pressure update rate

### Set Pressure Update Rate (0x37\_Cmd\_Set\_Pressure\_Update\_ms)

Mux Value Hex (Decimal): 0x37 (55)

Type: Sent to unit

Frequency: NOT APPLICABLE

Description: This message configures the unit's CAN message update rate in milliseconds of pressure values.

Layout:

Byte(s)	Data Type	Name	Description
0 – 2	Unsigned 24 bit integer	Unique ID	Unique ID
3	Unsigned 8 bit integer	Message Type	<b>0x37</b> – Set unit's pressure update rate
4 - 5	Unsigned 16 bit integer	Update Rate	10ms to 1000ms (10ms is default)

### Pressure Update Response (0x38\_Resp\_Pressure\_Update\_ms)

Mux Value Hex (Decimal): 0x38 (56)

Type: Transmitted from unit

Frequency: NOT APPLICABLE

Description: This is the unit's response to a set or get pressure update rate.

Layout:

Byte(s)	Data Type	Name	Description
0 – 2	Unsigned 24 bit integer	Unique ID	Unique ID
3	Unsigned 8 bit integer	Message Type	<b>0x38</b> – Gyro update rate response message
4 5	Unsigned 16 bit integer	Update Rate	10ms to 1000ms (10ms is default)

## R&D Battery Safety CAN Sensor User Manual

### Get Gas CAN message output on or off (0x3C\_Cmd\_Get\_Gas\_Msg\_On)

Mux Value Hex (Decimal): 0x3C (60)

Type: Sent to unit

Frequency: NOT APPLICABLE

Description: If this CAN message is sent the unit will respond with if the gas CAN message is on or off.

Layout:

Byte(s)	Data Type	Name	Description
0 – 2	Unsigned 24 bit integer	Unique ID	Unique ID
3	Unsigned 8 bit integer	Message Type	<b>0x3C</b> – Get gas CAN message setting on or off

### Set Gas CAN message output on or off (0x3D\_Cmd\_Set\_Gas\_Msg\_On)

Mux Value Hex (Decimal): 0x3D (61)

Type: Sent to unit

Frequency: NOT APPLICABLE

Description: This message configures if the unit's gas CAN message is on or off.

Layout:

Byte(s)	Data Type	Name	Description
0 – 2	Unsigned 24 bit integer	Unique ID	Unique ID
3	Unsigned 8 bit integer	Message Type	<b>0x3D</b> – Set unit's gas message to on or off
4	Unsigned 8 bit integer	On or Off	0 = off 1 = on (default)

### Gas CAN message output on or off Response (0x3E\_Resp\_Gas\_Msg\_On)

Mux Value Hex (Decimal): 0x3E (62)

Type: Transmitted from unit

Frequency: NOT APPLICABLE

Description: This is the unit's response to a set or get gas CAN message is on or off.

Layout:

Byte(s)	Data Type	Name	Description
0 – 2	Unsigned 24 bit integer	Unique ID	Unique ID
3	Unsigned 8 bit integer	Message Type	<b>0x3E</b> – gas message on or off response message
4	Unsigned 8 bit integer	On or Off	0 = off 1 = on (default)

## R&D Battery Safety CAN Sensor User Manual

### Get Water and Temperature CAN message output on or off (0x3F\_Cmd\_Get\_W\_and\_T\_Msg\_On)

Mux Value Hex (Decimal): 0x3F (63)

Type: Sent to unit

Frequency: NOT APPLICABLE

Description: If this CAN message is sent the unit will respond with if the Quaternion CAN message is on or off.

Layout:

Byte(s)	Data Type	Name	Description
0 – 2	Unsigned 24 bit integer	Unique ID	Unique ID
3	Unsigned 8 bit integer	Message Type	<b>0x3F</b> – Get water and temperature CAN message setting on or off

### Set Water and Temperature CAN message output on or off (0x40\_Cmd\_Set\_W\_and\_T\_Msg\_On)

Mux Value Hex (Decimal): 0x40 (64)

Type: Sent to unit

Frequency: NOT APPLICABLE

Description: This message configures if the unit's water and temperature CAN message is on or off.

Layout:

Byte(s)	Data Type	Name	Description
0 – 2	Unsigned 24 bit integer	Unique ID	Unique ID
3	Unsigned 8 bit integer	Message Type	<b>0x40</b> – Set unit's water and temperature message on or off
4	Unsigned 8 bit integer	On or Off	0 = off (default) 1 = on

### Water and Temperature CAN message output on or off Response (0x41\_Resp\_W\_and\_T\_Msg\_On)

Mux Value Hex (Decimal): 0x41 (65)

Type: Transmitted from unit

Frequency: NOT APPLICABLE

Description: This is response to a set or get water and temperature CAN message is on or off.

Layout:

Byte(s)	Data Type	Name	Description
0 – 2	Unsigned 24 bit integer	Unique ID	Unique ID
3	Unsigned 8 bit integer	Message Type	<b>0x41</b> – water and temperature on/off response message
4	Unsigned 8 bit integer	On or Off	0 = off (default) 1 = on

## R&D Battery Safety CAN Sensor User Manual

### Get Pressure CAN message output on or off (0x42\_Cmd\_Get\_Pressure\_Msg\_On)

Mux Value Hex (Decimal): 0x42 (66)

Type: Sent to unit

Frequency: NOT APPLICABLE

Description: If this CAN message is sent the unit will respond with if the pressure CAN message is on or off.

Layout:

Byte(s)	Data Type	Name	Description
0 – 2	Unsigned 24 bit integer	Unique ID	Unique ID
3	Unsigned 8 bit integer	Message Type	<b>0x42</b> – Get pressure message setting on or off

### Set Pressure CAN message output on or off (0x43\_Cmd\_Set\_Pressure\_Msg\_On)

Mux Value Hex (Decimal): 0x43 (67)

Type: Sent to unit

Frequency: NOT APPLICABLE

Description: This message configures if the unit's pressure CAN message is on or off.

Layout:

Byte(s)	Data Type	Name	Description
0 – 2	Unsigned 24 bit integer	Unique ID	Unique ID
3	Unsigned 8 bit integer	Message Type	<b>0x43</b> – Set pressure message to on or off
4	Unsigned 8 bit integer	On or Off	0 = off 1 = on (default)

### Pressure CAN message output on or off Response (0x44\_Resp\_Pressure\_Msg\_On)

Mux Value Hex (Decimal): 0x44 (68)

Type: Transmitted from unit

Frequency: NOT APPLICABLE

Description: This is the unit's response to a set or get pressure CAN message on or off.

Layout:

Byte(s)	Data Type	Name	Description
0 – 2	Unsigned 24 bit integer	Unique ID	Unique ID
3	Unsigned 8 bit integer	Message Type	<b>0x44</b> – pressure on or off response message
4	Unsigned 8 bit integer	On or Off	0 = off 1 = on (default)

## R&D Battery Safety CAN Sensor User Manual

### Get Air Temperature Offset (0x54\_Cmd\_Get\_AT\_Offset)

Mux Value Hex (Decimal): 0x54 (84)

Type: Sent to unit

Frequency: NOT APPLICABLE

Description: If this CAN message is sent the unit will respond with the current configured Air temperature offset value in degrees C.

Layout:

Byte(s)	Data Type	Name	Description
0 – 2	Unsigned 24 bit integer	Unique ID	Unique ID
3	Unsigned 8 bit integer	Message Type	<b>0x54</b> – Get unit's air temperature offset in deg C

### Set Air Temperature Offset (0x55\_Cmd\_Set\_AT\_Offset)

Mux Value Hex (Decimal): 0x55 (85)

Type: Sent to unit

Frequency: NOT APPLICABLE

Description: This message configures the unit's Air Temperature offset value, this is so the user can calibrate the air temperature reading that is out put on CAN.

Layout:

Byte(s)	Data Type	Name	Description
0 – 2	Unsigned 24 bit integer	Unique ID	Unique ID
3	Unsigned 8 bit integer	Message Type	<b>0x55</b> – Set unit's air temperature offset in deg C
4 - 7	Float	Deg C	-20 to 20 deg C

### Air Temperature Offset Response (0x56\_Resp\_AT\_Offset)

Mux Value Hex (Decimal): 0x56 (86)

Type: Transmitted from unit

Frequency: NOT APPLICABLE

Description: This is the unit's response to a set or get air temperature offset command.

Layout:

Byte(s)	Data Type	Name	Description
0 – 2	Unsigned 24 bit integer	Unique ID	Unique ID
3	Unsigned 8 bit integer	Message Type	<b>0x56</b> – units current offset value in deg C
4 - 7	Float	Deg C	-20 to 20 deg C (default = -6)

## R&D Battery Safety CAN Sensor User Manual

### Get Baseline Period (0x5D\_Cmd\_Get\_Baseline\_Period)

Mux Value Hex (Decimal): 0x5D (93)

Type: Sent to unit

Frequency: NOT APPLICABLE

Description: If this CAN message is sent the unit will respond with the time in seconds between reading a baseline value for the gas sensors.

Layout:

Byte(s)	Data Type	Name	Description
0 – 2	Unsigned 24 bit integer	Unique ID	Unique ID
3	Unsigned 8 bit integer	Message Type	<b>0x5D</b> – Get unit's Baseline period in seconds

### Set Baseline Period (0x5E\_Cmd\_Set\_Baseline\_Period)

Mux Value Hex (Decimal): 0x5E (94)

Type: Sent to unit

Frequency: NOT APPLICABLE

Description: This message configures the unit's between which baseline readings are taken for the gas sensors.

Layout:

Byte(s)	Data Type	Name	Description
0 – 2	Unsigned 24 bit integer	Unique ID	Unique ID
3	Unsigned 8 bit integer	Message Type	<b>0x5E</b> – Set unit's accelerometer update rate
4 - 5	Unsigned 16 bit integer	Seconds	60 to 10000 seconds (default = 1200)

### Baseline Period Response (0x5F\_Resp\_Baseline\_Period)

Mux Value Hex (Decimal): 0x5F (95)

Type: Transmitted from unit

Frequency: NOT APPLICABLE

Description: This is the unit's response to a set or get baseline period.

Layout:

Byte(s)	Data Type	Name	Description
0 – 2	Unsigned 24 bit integer	Unique ID	Unique ID
3	Unsigned 8 bit integer	Message Type	<b>0x3E</b> – Accelerometer update rate response message
4 - 5	Unsigned 16 bit integer	Update Rate	60 to 10000 seconds (default = 1200)

## BS\_Pressure (0x30B [default])

Default settings:

- CAN Start Address + 1 = (0x30B by default)
- Output rate is 10ms

Overview: This CAN message is used to output the unit's absolute pressure reading in millibar, it is extremely accurate between 300mbar and 1200mbar.

Layout:

Byte(s)	Data Type	Name	Description
0 - 3	Float	AbsolutePressureWide	Measures from 200mbar to 5500 mbar
4 - 7	Float	AbsolutePressureNarrow	Measures from 300mbar to 1200 mbar

## R&D Battery Safety CAN Sensor User Manual

### BS\_Water\_and\_Temp (0x30C [default])

Default settings:

- CAN Start Address + 2 = (0x30C by default)
- Output rate is 100ms

Overview: This CAN message is used to output the unit's air water content and air temperature information.

Layout:

Byte(s)	Data Type	Name	Description
0 - 1	Unsigned16 bit	AbsoluteHumidity	Absolute humidity Measured from 0 – 65535 mg/m <sup>3</sup>
2 - 3	Decimal 9 bit	RelativeHumidity	Relative humidity 0 to 105%
4 - 5	Decimal 9 bit	AirTemperature	Air temperature -30 to 225 Deg C
6 - 7	Decimal 9 bit	DewPointTemperature	Dew point temperature - Temperature at which condensation will start forming on an object which is at this temperature.

## BS\_Gas (0x30D [default])

Default settings:

- CAN Start Address + 3 = (0x30D by default)
- Output rate is set to 1000ms

Overview: This CAN message is used to output the unit's gas measurement values of equivalent CO<sub>2</sub> (eCO<sub>2</sub>), Volatile Organic Compounds (VOC), Ethanol and Hydrogen. (ethanol and hydrogen values are used to calculate eCO<sub>2</sub> and VOC values)

Layout:

Byte(s)	Data Type	Name	Description
0 – 1	Unsigned 16 bit	Ethanol	Ethanol in parts per million 0 – 1000 ppm
2 – 3	Unsigned 16 bit	H2	Hydrogen parts per million 0 – 1000 ppm
4 – 5	Unsigned 16 bit	EquivalentCO2	Equivalent CO <sub>2</sub> , equivalent means its referenced against a base line, these sensors baseline are factory calibrated, the sensor automatically baselines itself every 10 minutes.
6 – 7	Unsigned 16 bit	TotalVOC	Total Volatile Organic Compounds parts per billion 0 – 65535 ppb

## List of Tables

Table 1 Sensor Performance .....	5
Table 2 Environmental Performance Information .....	5
Table 3 Electrical Performance .....	6
Table 4 Connection Information .....	6
Table 5 CAN Message Output Summary .....	14
Table 6 CAN Configuration Message .....	15
Table 7 Configuration Message Types .....	16

## List of Figures

Figure 1 Mating Connector Pin Numbering (Top Down View) .....	7
Figure 2 Connector Crimp Details .....	7
Figure 3 JWPF Sensor Dimensions .....	8
Figure 4 Pigtail Sensor Dimensions .....	9
Figure 5 Mechanical Installation Orientation .....	10
Figure 6 Default CAN message output .....	12

End of Document